

## Installation and User Instructions

---

# RotaScope Classic Series

## Endoscope Drying Cabinet



## DISCLAIMER

Smartline Medical makes no representations or warranties with respect to this manual and, to the maximum extent permitted by law, expressly limits its liability for breach of any warranty that may be implied to the replacement of this manual with another. Furthermore, Smartline Medical reserves the right to revise this publication at any time without incurring an obligation to notify any person of the revision.

The information provided in this documentation contains general descriptions and/or technical characteristics of the performance of the products contained herein. This documentation is not intended as a substitute for and is not to be used for determining suitability or reliability of these products for specific user applications. It is the duty of any such user or integrator to perform the appropriate and complete risk analysis, evaluation, and testing of the products with respect to the relevant specific application or use thereof. Neither Smartline Medical nor any of its affiliates or subsidiaries shall be responsible or liable for misuse of the information that is contained herein. If you have any suggestions for improvements or amendments or have found errors in this publication, please notify us.

All pertinent state, regional, and local safety regulations must be observed when installing and using this product. For reasons of safety and to help ensure compliance with documented system data, Authorised Distributor technicians shall perform repairs to components.

When devices are used for applications with technical safety requirements, the relevant instructions must be followed.

Failure to observe this information can result in injury or equipment damage.

Smartline Medical has made every effort to prevent that the labelling, instructions for use, making available, putting into service and advertising of devices uses text, names, trademarks, pictures and figurative or other signs that may mislead the user or the patient regarding the device's intended purpose, safety and performance.

Copyright © 2021 by Smartline Medical

All rights reserved. No part of this publication may be reproduced, distributed, or transmitted in any form or by any means, including photocopying, recording, or other electronic or mechanical methods, without the prior written permission of the publisher. For permission requests, write to the publisher, addressed "Attention: Permissions Coordinator," at the address below.

Smartline Medical | 55 Cordwell Road, Yandina, Queensland, Australia, 4561  
+61 (07) 54789977 | [www.smartlinemedical.com.au](http://www.smartlinemedical.com.au), [sales@smartlinemedical.com](mailto:sales@smartlinemedical.com)

## TRADEMARKS

Smartline Medical has made every effort to supply trademark information about company names, products and services mentioned in this manual. Trademarks shown below were derived from various sources. All trademarks are the property of their respective owners.

General Notice: Some product names used in this manual are used for identification purposes only and may be trademarks of their respective companies.

## Table of Contents

1	PREFACE .....	8
1.1	....Description of the Operator .....	8
1.2	....Explanation of Safety Warnings.....	9
1.3	....Retaining Instructions .....	10
1.4	....Obtaining Documentation and Information .....	10
1.4.1	Internet.....	10
1.4.2	Ordering Documentation .....	10
1.4.3	Support and service .....	10
1.4.4	Name and address of the manufacturer .....	11
2	Description of the product.....	12
2.1	....Intended Use and Reasonably Foreseeable Misuse .....	12
2.2	....Process Overview .....	12
2.3	....Minimum System Requirements .....	13
2.4	....Technical Data (Performance characteristics of the RotaScope Cabinet) .....	14
2.5	....Product Compliance .....	14
2.5.1	Compliance Labels .....	14
2.6	....Product elements .....	17
2.6.1	RotaScope Cabinet Components .....	17
2.6.2	IAS Components .....	18
2.6.3	System Connection Overview.....	19
2.6.4	Internal Cabinet Components .....	20
2.7	....Understanding Product and Controls and Indicators.....	23
2.7.1	What is the product?.....	23
2.7.2	How does the product work? – Overview .....	23
2.8	....Understanding the User Interface.....	27
2.9	....Operating Panels of Cabinet Control Screens .....	27
2.9.1	Cabinet Control Screen.....	27
2.9.2	Endoscope Detail Display Screen.....	29
2.9.3	Control Screen .....	30
2.9.4	Environmental Display Screen .....	31
2.10	..Visual Signals at Cabinet.....	31
2.11	..Explanation of Auditory and Visual Signals on Cabinet System.....	32
2.11.1	Audio Signal at Cabinet Control Screen Loading and Unloading Scopes .....	32
2.11.2	Visual Signals at Control Screen .....	33

2.11.3	Labels at SmartStation (Print Station): .....	34
2.12.	<i>SmartStation Overview</i> .....	35
2.12.1	The SmartStation Touch Screen .....	36
2.12.2	Operation of the SmartStation located at the AER Scope Washer .....	37
2.12.3	Communication Kit (Part # COMMUNICATION KIT) .....	41
2.13.	<i>Scope Manager Software – Overview</i> .....	42
2.13.1	Installing Scope Manager Software .....	42
2.13.2	Using Scope Manager Software – Managing SCOPE ID BARCODES .....	43
2.13.3	Using Scope Manager Software – Managing OPERATOR ID BARCODES .....	44
3	Safety Instructions .....	45
3.1....	<i>How to Use the Product Safely</i> .....	46
3.1.1	Control screens, and electrical enclosures .....	46
3.1.2	Technical life span.....	46
3.1.3	PQ Performance Qualification .....	46
3.1.4	Safety information related to the intended use and reasonably foreseeable misuse.....	48
3.1.5	Personal Protective Equipment .....	49
3.1.6	Product limitations and restrictions .....	49
3.1.7	Maintenance safety information .....	50
3.2....	<i>General Anatomy of an Endoscope</i> .....	50
3.3....	<i>Scope Connector Hose Kits</i> .....	51
3.3.1	Scope Connector Hose Kits - Colour Coding:.....	52
3.3.2	Scope Connector Hose Kits – Cleaning IFU .....	53
3.3.3	Selecting Scope Connector Hose Kits, for your fleet of Scopes.....	54
3.3.4	Washer Rack Hose Connection Kit (Optional) .....	55
3.4....	<i>Cleaning of Cabinets IFU (Instructions For Use)</i> .....	56
3.4.1	Internal Surfaces Cabinet Cleaning IFU (Instructions For Use).....	57
3.4.2	Cleaning External Surfaces .....	58
3.4.3	Safe Disposal.....	59
3.5....	<i>Terms and definitions used in this manual</i> .....	60
3.6....	<i>Graphical Symbols</i> .....	68
3.6.1	Explanation of graphical symbols in relation to the product.....	68
3.7....	<i>Personal Protective Equipment</i> .....	69
4	PREPARATION.....	70
4.1....	<i>How to Transport and Store the Product</i> .....	70

4.1.1	Dimensions, mass and center of gravity .....	71
4.1.2	Lifting, handing and transporting the product.....	72
4.1.3	Storing the product during intervals in normal use.....	72
4.1.4	Securing the product against shocks .....	73
4.1.5	Securing the product against electrical shock.....	73
4.1.6	Securing the product against impact .....	73
4.2	<i>How to Install the Product</i> .....	74
4.2.1	Removal of the transport and packaging restraints – unpacking the cabinet from the crate .....	74
4.2.2	Free Standing Cabinet Wall Mount .....	75
4.2.3	Pass Through Units .....	75
4.2.4	Power Connection:.....	77
4.2.5	Packaging contents .....	77
4.2.6	Verification of the product .....	78
4.2.7	Minimum space needed.....	79
4.2.8	Layout plan .....	80
4.2.9	Data and Power Schematic .....	81
4.2.10	Required Tools .....	82
4.3	<i>How to Commission the Product</i> .....	82
4.3.1	Installation of the software.....	82
4.3.2	Calibration of the device .....	82
5	OPERATION/USE Verification.....	83
5.1.1	Verification of correct installation.....	83
5.1.2	Verification of correct maintenance.....	83
5.1.3	Verification of correct cleaning/disinfection. ....	83
5.1.4	Operational environment .....	83
5.1.5	Using the device in combination with other devices.....	83
5.1.6	Instructions for devices emitting hazardous radiation.....	83
5.1.7	Instruction for devices that are composed of substances or of combinations of substances that are intended to be introduced into the human body .....	83
5.1.8	Manual operating techniques.....	83
5.1.9	Starting/Stopping the product operation.....	84
5.2	<i>How to Use the Product Remotely/Automatically</i> .....	84
5.3	<i>What to Do in Emergency and Exceptional Situations</i> .....	84
6	MAINTENANCE.....	85
6.1.1	Planned maintenance of RotaScope. ....	85

6.2....	<i>How to Inspect the Product</i> .....	85
6.2.1	Weekly inspection tasks .....	85
7	TROUBLESHOOTING AND REPAIR .....	86
7.1....	<i>How to Identify and Solve Problems</i> .....	86
7.1.1	Troubleshooting and repair by non-skilled persons.....	86
7.2....	<i>Frequently Asked Questions</i> .....	87
7.3....	<i>Repair</i> .....	87
7.3.1	Repair by skilled persons.....	87
8	DISPOSAL.....	88
8.1....	<i>How to Disassemble the Product</i> .....	88
8.2....	<i>How to Recycle Parts</i> .....	89
8.3....	<i>How to Dispose the Product</i> .....	89
8.3.1	Test procedure to facilitate safe disposal of the device and related waste substances.....	89
8.3.2	Disposal of the device .....	90
8.3.3	Disposal of waste substances: .....	90
8.3.4	Disposal of electronic components .....	90
8.3.5	Disposal of packaging waste.....	90
8.3.6	Disposal of batteries.....	91
9	APPENDIX I – SUPPLIED ACCESSORIES, CONSUMABLES AND SPARE PARTS .....	92
9.1....	<i>Supplied accessories</i> .....	92
9.2....	<i>Consumables</i> .....	92
9.3....	<i>Spare/replacement parts</i> .....	92
10	DECLARATION OF CONFORMITY FOR CLASS I DEVICE.....	95

## **1 PREFACE**

### **1.1 Description of the Operator**

The RotaScope Endoscope Drying Cabinets are designed for Drying of Endoscopes after reprocessing in healthcare environments.

The Operator is a Trained and Authorized person, who consistently operates the RotaScope and its approved accessories, and/or performs the unloading/loading of the Endoscopes in the RotaScope.

The User must not tamper or modify the RotaScope.

Any modifications, servicing, or repairs must be done by a Smartline Medical Trained Professional or a Trained Professional that is under instruction from Smartline Medical.


This document is intended for the User and Smartline Medical Trained Professionals of the RotaScope, accessories and software.

Authorised Distributors are approved by Smartline Medical Pty Ltd for sales, and technical support



## 1.2 Explanation of Safety Warnings

The following Safety Precautions must be observed when operating or servicing the RotaScope. For emphasis, certain Safety Precautions are repeated throughout the manual. It is important to review ALL Safety Precautions before operating or servicing the unit.

Warning Cabinet	
<div style="text-align: center; background-color: orange; color: black; padding: 10px; width: fit-content; margin: auto;"><b>WARNING</b></div>	<ul style="list-style-type: none"> <li>Cabinet to be installed and levelled by an Approved Distributor</li> <li>Only Approved Distributors may install, service or repair Smartline Medical equipment</li> <li>Avoid contact of electrical components with water and moisture.</li> <li>Do not connect to any external electronic devices.</li> <li>Do not lean on cabinet.</li> <li>HEAVY! Do not lift cabinet without lifting equipment</li> </ul>
Warning Integrated Air System	
<div style="text-align: center; background-color: orange; color: black; padding: 10px; width: fit-content; margin: auto;"><b>WARNING</b></div>	<ul style="list-style-type: none"> <li>Machine Noise: 47 Decibels maximum measured at 1 Meter distance</li> <li>Only Approved Distributors may install, service or repair Smartline Medical equipment</li> <li>Avoid contact of electrical components with water and moisture.</li> <li>High voltage 240V</li> <li>Do not remove covers or guards</li> </ul>
	<ul style="list-style-type: none"> <li>Do not look directly into beam of barcode scanner</li> </ul>

### 1.3 Retaining Instructions

Read and understand this manual and its safety instructions before using this product. Failure to do so can result in serious injury or death.

Follow all the instructions. This will avoid fire, explosions, electric shocks, or other hazards that may result in damage to property and/or severe or fatal injuries.

The product shall only be used by persons who have fully read and understand the contents of this user manual.

Ensure that each person who uses the product has read these warnings and instructions and follows them.

Keep all safety information and instructions for future reference and pass them on to subsequent users of the product.

The manufacturer is not liable for cases of material damage or personal injury caused by incorrect handling or non-compliance with the safety instructions. In such cases, the warranty will be voided.

### 1.4 Obtaining Documentation and Information

#### 1.4.1 Internet

The latest version of the documentation is available at the following address:

<http://www.smartlinemedical.com>

#### 1.4.2 Ordering Documentation

Where multiple devices are supplied usually a single copy of the Instructions For Use is provided - further copies can be provided free of charge upon request.

Documentation, user instructions and technical information can be ordered by calling Smartline Medical on +61 (07) 5478 9977

#### 1.4.3 Support and service

For information about:

- Publications and materials
- Information, technical assistance or ordering user instructions
- Service-related questions

Smartline Medical | 55 Cordwell Road, Yandina, Qld, 4561  
+61 (07) 54789977 | [www.smartlinemedical.com.au](http://www.smartlinemedical.com.au)

**1.4.4 Name and address of the manufacturer**

The following natural or legal person makes the device, to which this user manual applies, suitable for use within the European Union and is considered to be the manufacturer of the device:

Smartline Medical | 55 Cordwell Road, Yandina, Qld, 4561  
+61 (07) 54789977 | [www.smartlinemedical.com.au](http://www.smartlinemedical.com.au)

## 2 Description of the product

### 2.1 Intended Use and Reasonably Foreseeable Misuse

This RotaScope has been designed to dry and store up to nine Flexible Thermolabile Endoscopes.

The RotaScope is intended to be used for Operators in a healthcare environment to store and dry Thermolabile Endoscopes after being reprocessed.

The RotaScope shall not be used for any other function except for the storing and drying of Thermolabile Endoscopes.

The RotaScope shall be used with the following original accessories and components only:

- SmartStations
- Communications Kit (including the export version – excluding laptop)
- Endoscope Hang Hooks
- Optional - Approved Endoscope Hose Connection Kits (Purchased Separately)
- ScopeManager software application

It is essential that the user of this manual is aware of the potential hazards associated with the unit and its accessories. All operators should be familiar with the safety precautions and warnings given in this section prior to attempting to operate the unit. If the unit is used in a manner not specified by the manufacturer, the protection provided by the equipment may be impaired.

### 2.2 Process Overview

The RotaScope Data System functions on a Linux system and Barcode Scanners. The system functions on the concept of WHO, WHAT and WHERE, with WHEN being automatically captured by the Data System.

- WHO = Operator ID Barcode
- WHAT = Scope ID Barcode
- WHERE = Device/Function Barcode

#### **AER Validation:**

- WHO - Operator ID – the person that washed the scope in the AER
- WHAT - Which Scope
- WHERE - Where the scope was washed (Washer/AER Chamber)
- The Scope is loaded into the AER

## Storage Information:

- WHO – (The Operator ID Barcode) – the person that stored the scope in the Cabinet
- WHAT - Which Scope (Scope ID Barcode)
- Into the Cabinet (Cabinet Name) E.g. Cabinet 2, Location 3 (Hook Number)
- “Scope Storage Count Down Timers” seen on the Cabinet Control Screen located on the cabinet door/s, may be used to determine which scope has the least remaining storage time. Utilising this “First In– First Out” principle will help reduce reprocessing costs and deliver operational efficiency and save time and costs.
- Out of the Cabinet

## 2.3 Minimum System Requirements

Computer and Processor	1.1 gigahertz (GHz), 64-bit dual-core processor
Operating System	Windows 10  NOTE: The Scope Manager Software is to be installed on a laptop or via a local a PC (with Wi-Fi)  The operating system is an integral part of the cabinets and SmartStation data system - using a Smartline Medical supplied COMMUNICATION KIT is preferred.
Memory (RAM)	4 gigabyte (GB) RAM (64-bit)
Auxiliary parts	Barcode reader, Wireless mini-USB adaptor
Data	Point to Point or looped Cat6 Data cabling between devices
Power	110 – 240V at each device (Cabinets and Printers)

## 2.4 Technical Data (Performance characteristics of the RotaScope Cabinet)

Parameter	Unit
Device name	RotaScope Classic Series
Designation	Class 1
Type	Endoscope Storage Cabinet
UNSPC Commodity Code	42295002
Customs HS Code	9018908400
Technical life span	7 Years
Expiry Date	N/A
Capacity	Up to nine (9) endoscopes
Energy consumption	250W
Size (Mass)	2363mm H x 600mm W x 600mm D – Base Cabinet
Weight	140 kgs (308 lbs)
Chemical composition	Various
Performance data	Validated to 31 Days Endoscope Drying and Storage
Services Supply	220V-240V 10A or 110-120V 15A
Emission of noise	47 dB measured at 1m
HEPA Quality	H13: 0.2 micron 99.99% efficiency
Altitude	Up to 2000m
Overvoltage Category	Category II

## 2.5 Product Compliance

This product complies to all known relevant European Directives. The Declaration of CE Conformity can be found in the Appendix at the end of this manual. The Products comply with the following relevant product safety standards:

- AS/NZS 4187: 2014
- EN 16442: 2015
- ISO-9001
- CE
- EMC Tested IEC 60601-1
- IEC 61010-1 Safety Tested

### 2.5.1 Compliance Labels

**RotaScope Cabinet** – Compliance Label affixed at top front of cabinet behind the façade.

IAS Label is fitted to the side of the IAS.

SmartStation Label is fitted to the side of the SmartStation – see labels below

### 2.5.1.1 RotaScope Cabinet Product Compliance Label



#### RotaScope iQ Cabinet Pass Through

Product Code: ROTA-IQ-P  
This product is designed to store and facilitate drying endoscopes in accordance with EN16442:2015

Model No:                      Serial No:  
ROTA-IQ-P                      0001

Imported and Distributed by:

Manufactured by:  
SMARTLINE MEDICAL PTY LTD  
55 Cordwell Road, YANDINA, Queensland,  
Australia



IEC 61010-1 Safety Tested  
EMC Tested  
EN16442:2015 Compliant



High Voltage - Input 110 - 240v AC (50-60Hz)  
Rated current -  
15A at 110v  
6.3A at 240V

Select IEC Input Power Cable to suit power outlet of your country.

Replacement Fuses:  
240v - 6.3A RS-STOCK NO: 563-706  
110v - 15A RS-STOCK NO: 611-0030  
Machine Noise 47 Decibels measured at 1m

Do not remove covers or guards.

Only Smartline Medical Pty Ltd approved service technicians to install, service or repair electrical equipment.

Refer to the Operations Manual for instruction for use.

For Technical Support please visit [www.smartlinemedical.com](http://www.smartlinemedical.com)



Located at the top front of the Cabinet behind the façade

### 2.5.1.2 Integrated Air System Compliance label



#### Integrated Air System

Product Code: IAS  
This product is designed to store and facilitate drying endoscopes in accordance with EN16442:2015

Model No:                      Serial No:  
IAS                                      4527

Imported and Distributed by:

Opritech (NZ) Ltd

Manufactured by:  
SMARTLINE MEDICAL PTY LTD  
55 Cordwell Road, YANDINA, Queensland,  
Australia



IEC 61010-1 Safety Tested  
EMC Tested  
EN16442:2015 Compliant



High Voltage - Input 110 - 240v AC (50-60Hz)  
Rated current -  
15A at 110v  
6.3A at 240V

Select IEC Input Power Cable to suit power outlet of your country.

Replacement Fuses:  
240v - 6.3A RS-STOCK NO: 563-706  
110v - 15A RS-STOCK NO: 611-0030  
Machine Noise 47 Decibels measured at 1m

Do not remove covers or guards.

Only Smartline Medical Pty Ltd approved service technicians to install, service or repair electrical equipment.

Refer to the Operations Manual for instruction for use.

For Technical Support please visit [www.smartlinemedical.com](http://www.smartlinemedical.com)



Located on the right rear side of the IAS on top of the cabinet

### 2.5.1.3 SmartStation Compliance Label

Printer Control Station **SMARTLINE**  
MEDICAL

Manufactured by:  
Smartline Medical Pty Ltd  
DC 12V 1A



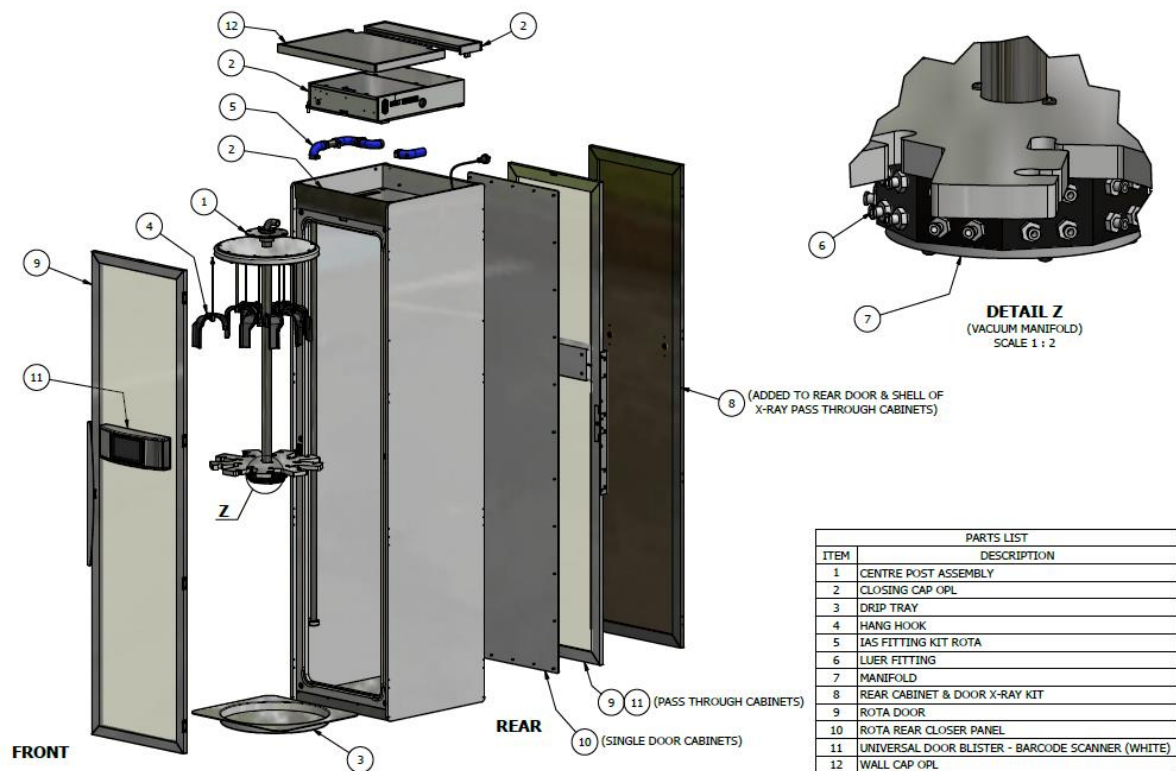
(01)9356523000443(11)210721(10)A26546(21)0004

Located on the side of the SmartStation mounting enclosure



## 2.6 Product elements

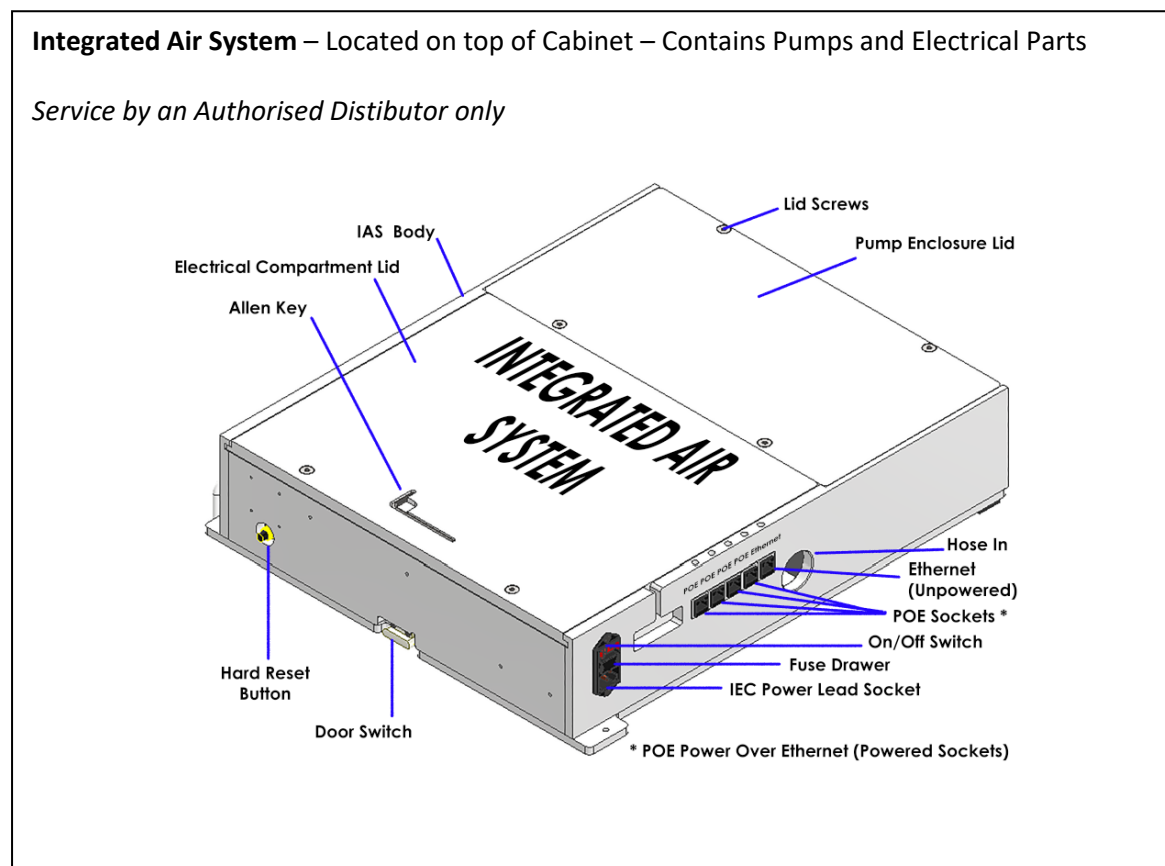
### 2.6.1 RotaScope Cabinet Components



\*The Cabinet may be configured with a Rear Door if it is the Pass-Through version

\*\*The Cabinet may also include an X-Ray Kit on the rear door to prevent transmission of the X-Ray through the cabinet.

## 2.6.2 IAS Components



Located on the top of the drying cabinet, the Integrated Air System (IAS) is an assembled unit that provides the vacuum and HEPA filtered air for the drying function of the cabinet.

The IAS contains pumps, and control equipment including the data system, and termination points for connection to mains power and to the system network and devices.

The 4 POE ethernet ports (located on the right side) are for connecting Ethernet cables (CAT 6) from the cabinet to other cabinets, and for connecting SmartStation units.

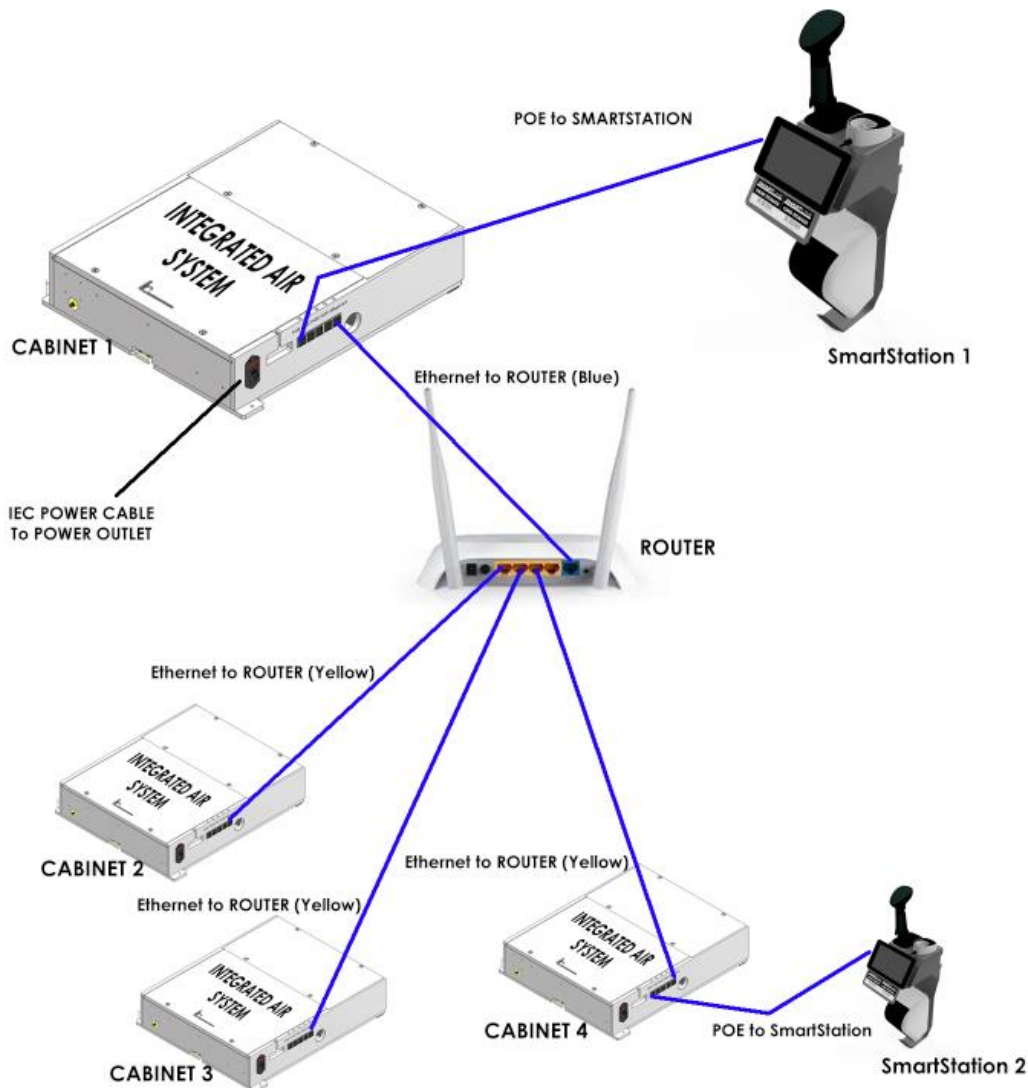
A router device may also be connected to the (unpowered) ethernet socket to enable multiple cabinets to be connected. The router also enables technicians to remotely login to the data system for service and support purposes.

**NOTE:** When connecting multiple cabinets, it is important to connect via the router enabling remote access.

## 2.6.3 System Connection Overview

### Connecting Devices – Data Network Overview

- On the diagram below – the IAS represents a Cabinet
- Each Cabinet has an IAS Integrated Air System



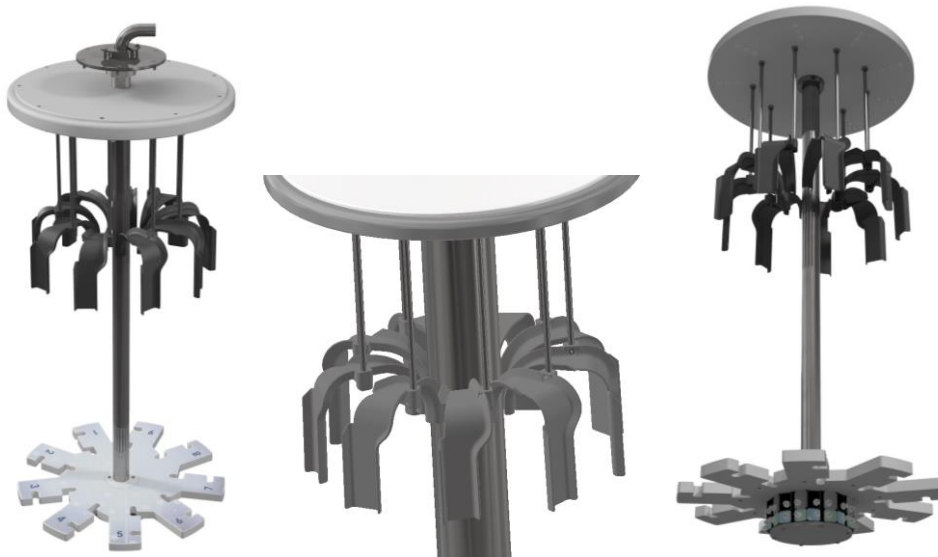
The connecting Ethernet cables may be linked directly as drawn or via Point to Point wall sockets as specific to your site design – please confirm your site specific layout details when ordering.

- The ROUTER connects multiple Cabinets
- The ROUTER enables remote access for service and support
- The ROUTER should be connected to the Port labelled **Ethernet** on the IAS at the top of the cabinet

## 2.6.4 Internal Cabinet Components

### 2.6.4.1 Identifying the Hang Hook and Connection components

#### The RotaScope Centre Pole, Hang Hooks and Vacuum Manifold



A rotating Centre Pole is located inside each RotaScope cabinet. Up to 9 Endoscopes are vertically hung on numbered Hang Hooks. The Hang Hooks are designed to be easy to load, gentle on scopes and easy to clean. Hang Hooks may be adjusted high or low for Long or Short Scopes and easy access. The Centre Pole can be manually rotated for scope selection.



The Vacuum Manifold (above left) is the point that each scope is connected to the cabinet airflow via the Scope Hose Connection Kits (described later in this document).

The Top Plate (Top Disk) retains the Hang Hooks and has vacuum airflow Luer Fittings for connecting scopes via the Scope Connector Hose Kits – the Top Plate is Numbered for scope location.

The Centre Disk (1) retains scope lumens and is numbered for scope location identification.

## 2.6.4.2 Hang Hooks – options

A RotaScope Cabinet Centre Pole may be fitted with various hooks to store different scopes



**Image above left shows an ENT Hang hook and optional 51.SC12-ENTH Cable Hang Hook**

**Image above right shows a standard hang hook** which is provided as High or Low version via a long and short stainless hang rods which are set up at install to suit your scopes.

Various ENT Hooks are available, and an Authorised Distributor will assist you with ordering special needs hang hooks will hold most types of flexible scopes

A mix of ENT and Standard Hang Hooks may be used in a cabinet at the same time

NOTE: Where mixed hang hooks are located in one cabinet, it will be necessary to assign the scope to a particular location (Position Number) when setting up the scope locations in the Scope Manager Software

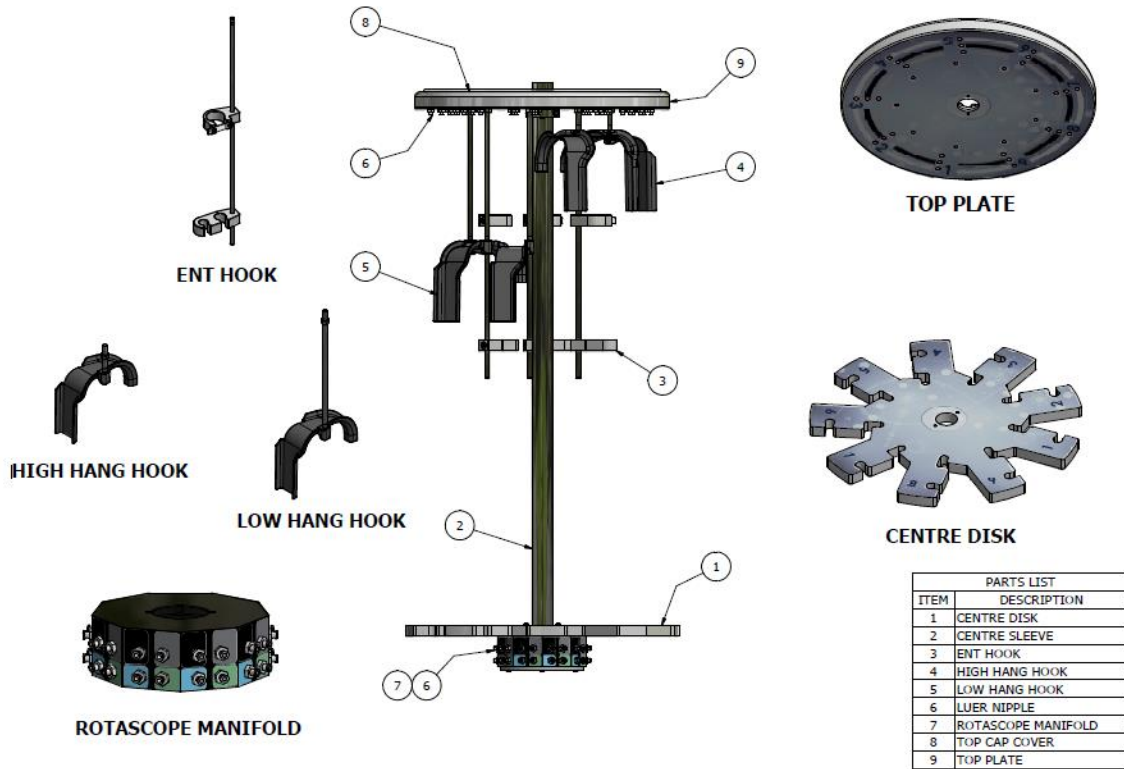
Cleaning hooks regularly is important – see “**Cabinet Cleaning**” which is described later in this document

*Weekly Cabinet Cleaning is described later in this document*

## 2.6.4.3 RotaScope Centre Pole and Manifold Details

### RotaScope Centre Pole: OVERVIEW:

The Top Disk of the centre pole



The hang hooks may be selected to suit various types and lengths of scopes

Please see your Authorised Distributor for assistance in better understanding the various Hang Hook Options to make hanging scopes easy and safe

## 2.7 Understanding Product and Controls and Indicators

### 2.7.1 What is the product?

RotaScope is an approved Medical Drying and Storage Cabinet for drying the outside surfaces and internal tubes in flexible medical endoscopes.

RotaScope Cabinets hold up to nine endoscopes on Hang Hooks located in the cabinet (Vertical storage of endoscopes)

### 2.7.2 How does the product work? – Overview

Room air, from an airconditioned room, is drawn into the cabinet via air pumps (miniature side channel blower vacuum pumps).

The pumps push room air through HEPA filters into the cabinet to dry the outside surfaces of the Endoscopes.

Scopes have up to seven tiny tubes (Lumens) that run through the inside of the scope to deliver air, water, gas and instruments into the patient. These tubes need to be dried after a scope is washed, to prevent any tiny remnants of biofilm or free radical bugs from proliferating.

After reprocessing, in simple terms, “A dry scope is a good scope”.

For each stored scope, there are 7 small luer hose connection nipples located on the manifold and Top Disk of the centre pole.

The manifold provides vacuum that draws air through the small hoses that run inside of the endoscope to dry each tiny channel tube (Lumen).

**Scope Connector Hose Kits have** special connectors fitted, that allow one end of the **Scope Connector Hose** to join to ports on the scope, whilst the other end connects to the cabinets vacuum manifolds. The hoses are colour coded to match the coloured sticker icons on the manifold and top disk, to ensure the hoses are connected to the correct fitting.

In this way the air system sends HEPA filtered air into the cabinet (dries the outside of the scopes), whilst sucking some of that filtered cabinet air out through the scope channels (drying the insides of the scope).

Scopes can be continuously stored up to an independently approved storage time of 31 Days in the cabinet. (Complies with European Drying Cabinet Standard EN16442:2015)

## Digital data capture: Stored in an SQL Database

The cabinets are controlled by a Linux Device (Miniature computers) and use of barcode readers and viewed on the **Cabinet Control Screen**, located on the cabinet door. The system captures data about:

- Operator (Staff Barcode Name Tags)
- Scope details (Scope ID Barcode Sticker)
- Date
- Time
- Scope location (which position the scope is stored in)
- Scope storage duration (Maximum time a scope may be stored)
- **Out of Cabinet Time** (OOC)- If a scope is removed and replaced, the data system counts the time the scope outside of the cabinet, which must be less than 3 hours, so that remnant biology does not tend to proliferate
- Cabinet internal air pressure
- Cabinet humidity
- Cabinet internal temperature
- Other data is captured includes, pump temperature, motor speeds, door sensors and other controls
- Alarms via lighting, data records and printed notifications occur for various warning methods and record keeping

## Operation of the cabinet: Short Description for Loading a Scope

### At AER Washer:

- Scan the scope out of the AER via the SmartStation to validate that a scope was washed (Scan Operator ID Barcode, then scan Scope ID Barcode, then scan Chamber ID Barcode located on the Washer). (Audio prompt "LONG WASH" or "SHORT WASH")
- Collect Printed Sticker from SmartStation Printer (SCOPE WASH RECORD)

### At Cabinet:

- Scan Operator ID Barcode on Cabinet Controller Barcode Scanner located on front or rear door blister – Cabinet door unlocks (Audio Prompt "OPERATOR")
- Scan Scope ID barcode as above (Audio Prompt "SCOPE")
- Open door
- Load scope (Place Scope On Hang Hook)
- Connect various hoses from vacuum manifold to scope ports (Colour coded hoses match-coloured stickers on manifold)
- Close door – door locks (Audio Prompt "SCOPE LOADED POSITION X")
- See Main Screen for location and status of loaded scope

### Cabinet Environment details can also be seen:

- **Main Screen**, shows individual details about drying status,
- Cabinet environment is also shown on Main Screen displaying Temperature in the cabinet, Pressure in the cabinet, Humidity in the cabinet



- Air system details can be seen on the “Information screen” displaying motor speed, temperature, and other details

### About the drying principles:

The cabinet runs at about 8 degrees Celsius warmer than the room it is located in.

The warmer air in the cabinet is dryer than the room air at about 20% RH below, due to the elevated cabinet temperature.

Bulk loose water in Scope Channels is generally removed by airflow in about 10 minutes.

Standards dictate that a scope must be dried in less than 3 hours to limit possible microbiological proliferation.

Remaining trapped moisture droplets typically found in capillary hose joins and ports will dry in about 1.5 hours from time of loading a scope

The scope channels usually DRY in under 1.5 hours

The slowest part of a scope to dry is the external control knobs on the scope control handpiece which can take up to three hours – less if patted dry with clean, lint free cloth before loading

For best results Smartline recommends purging bulk moisture out of scopes before loading, by use of medical air gun to blow out channels manually

Typical Humidity at normal preferred operation conditions:

Room Temperature	Room Humidity	Absolute Water Content
22 Degrees C	Approximately 60%	0.012 kg/m <sup>3</sup>
Cabinet Temperature	Cabinet Humidity	Absolute Water Content
30 Degrees C	39.5%	0.012 kg/m <sup>3</sup>

### Vacuum air flow through scopes:

RotaScope uses a patented concept of drawing air through the scope via vacuum instead of blowing air through the scope channels for drying.

Elevated temperature and Vacuum (in theory) can assist in drying faster.

By using vacuum, infection control is better, as the connecting hoses are on the exit side of the air flow through the scopes.

Air is drawn into the distal tip (camera end of the scope which goes into the patient) from the distal tip air is drawn through the scope channels (lumens), then through the Scope Connection Hose Kits to the cabinet vacuum manifold.

The benefit of this airflow pathway is that the air passes through the scope channels individually to each set of sensors for each channel port of the manifold sensor board.

Some scope channels are Y junctions – despite the joins each channel is seen independently as the air is drawn from each port so that there are no amalgamated air flows, thus the cabinet can dry each channel or section of scope channel independently.

**Cabinet/environmental conditions:**

Recommended that the cabinet is located in room with constant air conditioning at 22 degrees C (maximum 38 degrees C)

Recommended Room Humidity <90%

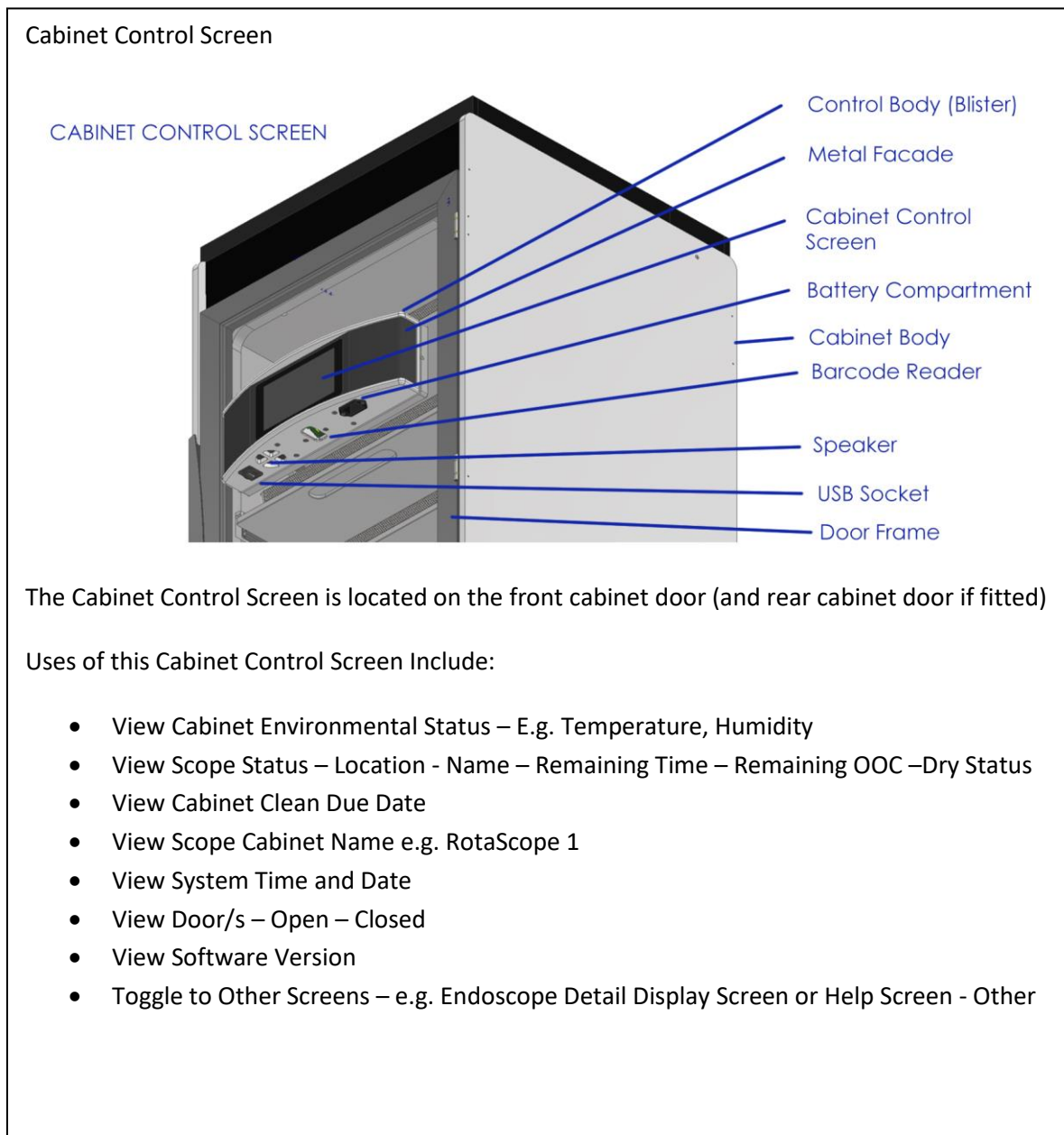
Cabinet Internal Operating Temperature 22-45 Degrees C – (Usually 30-37)

Cabinet internal pressure approximately +15 Pa, Vacuum in Air System – approximately -17,000 Pa.

Cabinet Humidity is usually around 10 - 45% depending on room humidity and temperature.

## 2.8 Understanding the User Interface

The following images outline the display screens on the cabinet.

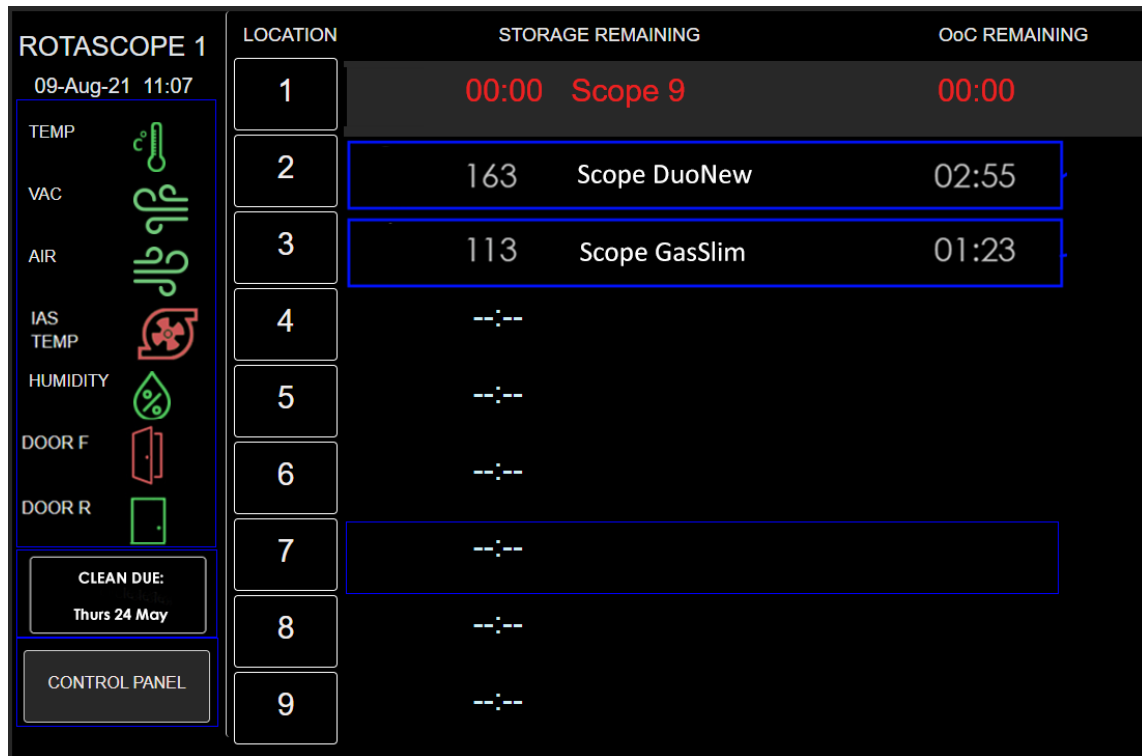


## 2.9 Operating Panels of Cabinet Control Screens

### 2.9.1 Cabinet Control Screen

The **Cabinet Control Screen** is the main display and control panel for viewing and managing the cabinet. The Cabinet Control Screen is a Touch Screen – the Touch Screen is used to navigate to further Detail Screens by touching the section that you want further information about e.g. Control Panel

**Main Screen:** Note: Blue Rectangles shown navigate to other screens when pressed

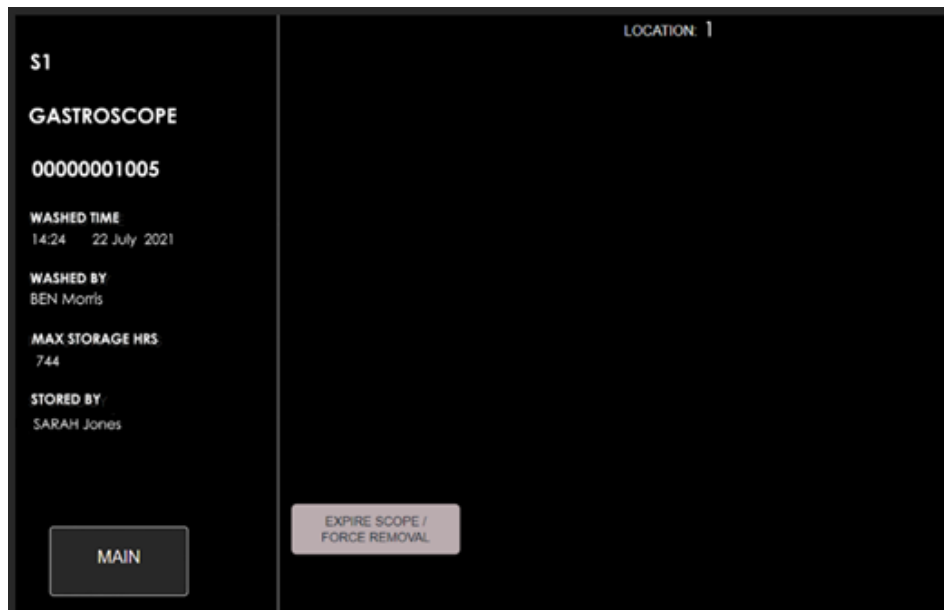


The **Main Screen** has quick look icons and readings for a clear overview, to get more detail on a topic each area acts as a button to the detail screen. (Press the relevant Icon – see below)

	<p>Coloured icons indicate status: E.g. - RED colour indicates <b>Over temperature</b></p> <p>CHECK CABINET – <i>Press to go to detail screen</i></p>
	<p>Scope status is indicated by Colour.</p> <p>RED if there is a problem or if expired</p> <p>REPROCESS SCOPE – <i>Press to go to detail screen</i></p>
	<p>WHITE if the scope is fit for use</p>
	<p>--:-- Indicates No Scope Loaded</p>
	<p>RED if door is open for too long (&gt; 2 minutes)</p> <p>Door closed- GREEN – OK</p>

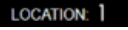


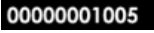





## 2.9.2 Endoscope Detail Display Screen

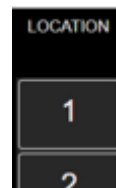
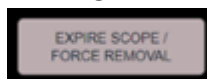
Endoscope Detail Display Screen shown below: Classic Cabinet Series



Features shown include:

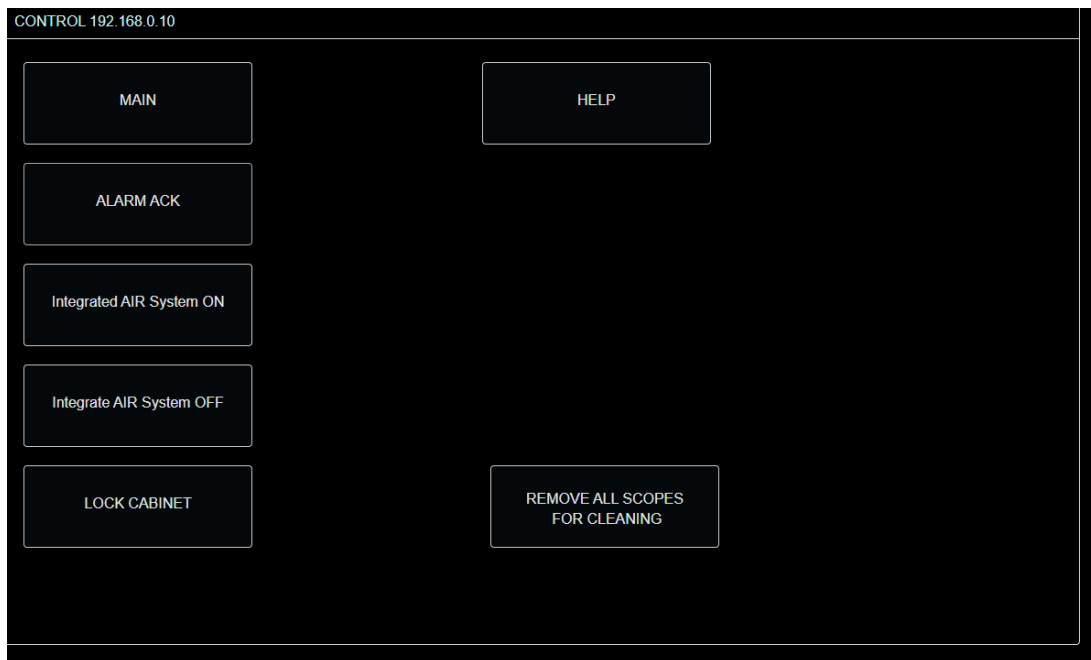
Pressing the Location 1-8 Button on the Main Screen will take you here .....

- LOCATION e.g. "Location 1" (Hook) 
- SCOPE NAME e.g. "S1" 
- SCOPE TYPE e.g. "GASTROSCOPE" 
- SCOPE SERIAL NO. e.g. "00000001005" 
- WASH TIME e.g. "14:24 22 July 2021" (Time and Date) 
- WASHED BY e.g. Ben Morris (Who Unloaded AER Washer) 
- MAX STORAGE HRS e.g. "744" (Storage Duration from AER unload) 
- STORED BY e.g. "SARAH Jones" (Operator Name ID) 
- MAIN – press to return to the "Main Control Screen" 
- EXPIRE SCOPE / FORCE REMOVAL – Press to remove all scopes at one time when cleaning cabinet weekly – see Cabinet Cleaning Instructions in this manual



## 2.9.3 Control Screen

The Control Screen is the place to action features:



### Features:

- MAIN – Press to return to Main Screen
- ALARM ACK – Press to Acknowledge Alarms – Resets the coloured lights to Green
- Integrated AIR System ON/OFF - Press to Turn Air System ON/OFF
- LOCK CABINET – Press to Lock the cabinet (Use Operator ID Barcode Tag to scan to Unlock)
- HELP – Press for further help
- REMOVE ALL SCOPES FOR CLEANING – Press to remove all scopes for weekly cabinet cleaning

### The user features are:

- HELP Button that leads to the Help Display which features cheat sheets, troubleshooting and instructional videos.
- REMOVE ALL SCOPES FOR CLEANING Button, which is a shortcut that allows the user to digitally remove all endoscopes from the cabinet prior to a weekly cleaning process.

## 2.9.4 Environmental Display Screen


ROTASCOPE 1	VALUE	MIN	MAX
TEMPERATURE	30.3	10.0	40.0
VAC	-15420.5	-20000.0	-6000.0
AIR	0.0	-10.0	27.0
IAS PUMP1 TEMP	0.0	10.0	58.0
IAS PUMP1 RPM	0.0	N/A	
IAS PUMP2 TEMP	0.0	10.0	58.0
IAS PUMP2 RPM	0.0	N/A	
HUMIDITY	46.7	3.0	90.0
DOOR F	CLOSED		3MINS
DOOR R	CLOSED		3MINS

MAIN

The Environmental Display has the current readings from environmental sensors. The MIN (Minimum) and MAX (Maximum) values, where applicable are displayed to the right.

## 2.10 Visual Signals at Cabinet











Cabinet Environmental Lighting changes with status and errors are displayed on screen and errors are printed via the SmartStation Printer.

 Cabinet coloured lighting indicates overall cabinet status as below:






## 2.11 Explanation of Auditory and Visual Signals on Cabinet System

### 2.11.1 Audio Signal at Cabinet Control Screen Loading and Unloading Scopes

Audio Signals at Cabinet Control Screen				
No	Icon	Description	Location	Tone
1.		Scan Operator ID Barcode (Staff ID Badge) - Unlocks door  Audio Tone - <b>“Operator”</b>	Door Control Screen	Voice 
2.		Scan Scope ID Barcode  Audio Tone - <b>“Scope”</b>  (See SmartStation section below) (Scope must have been scanned out of an AER – i.e. Clean)	Door Control Screen	Voice 
3.		Cabinet Cleaning - Scan Operator ID Barcode (Staff ID Badge) - Audio Tone - <b>“Operator”</b> - then press Cabinet Clean Button on Main Screen  Audio Tone - <b>“Cleaned”</b>  Used when cleaning cabinet weekly	Door Control Screen	Voice 
4.		Loading a Scope – Scan Operator ID Barcode (Staff ID Badge) Audio Tone - <b>“Operator”</b>  Scan Scope ID Barcode - Audio Tone - <b>“Scope”</b>  Open Door - Load Scope and Connect Scope Hose Connection Kits – Close Door - Audio Tone - <b>“Scope, Stored, Location X”</b>	Door Control Screen	Voice 
5.		Unloading Scope – Scan Operator ID Barcode (Staff ID Badge) Audio Tone - <b>“Operator”</b> – Disconnect and remove scope – Close Door – Scan Scope ID Barcode  Audio Tone - <b>“Scope, Location X, Removed”</b>	Door Control Screen	Voice 



## 2.11.2 Visual Signals at Control Screen

Visual Signals at Cabinet Control Screen				
No	Icon	Description	Location	Type
1.		The Cabinet Control Screen – Located on Front or Rear Doors is the main visual location to see the Cabinet Status and Stored Scope Status - Various information is available by navigating through touch activated screens	Cabinet Control Screen	Screen Display
		<p>Cabinet <b>Clean Due Date</b> – Located on Cabinet Control Main Screen</p> <p>Clean Due Date advances by 7 days when Operator Staff ID Barcode is scanned followed by</p> <div style="border: 1px solid black; background-color: black; color: white; padding: 5px; text-align: center; width: fit-content; margin: 10px auto;"> <p><b>CLEAN:</b> Thu 29-Jul</p> </div> <p>pressing Cabinet Clean Button</p> <p> <b>Cabinet Clean Record</b> prints at printer located on the SmartStation</p> <div style="border: 1px solid gray; border-radius: 10px; padding: 10px; width: fit-content; margin: 10px auto;"> <p style="text-align: center; margin: 0;"><b>CABINET CLEAN RECORD</b></p> <p style="font-size: small; margin: 0;">Cabinet: ROTASCOPE 1 Date: 08:07:52 Jan-06 20 User: RICHARD</p> <p style="font-size: x-small; margin: 0; text-align: center;">www.smartlinemachinery.com</p> </div> <p>NOTE: When a Cabinet Clean is DUE then the cabinet lighting will turn BLUE and will revert to GREEN after the Cleaning Cycle is completed</p>		

### 2.11.3 Labels at SmartStation (Print Station):



See labels below

Wash Label	Cabinet Clean Record
<div data-bbox="248 465 555 674" style="border: 1px solid black; border-radius: 15px; padding: 10px;"> <p><b>SCOPE WASH RECORD</b>  SCOPE TYPE: ENDOSCOPE  SCOPE NAME: scope 4  WASHER: AER 1  LOADED TIME: 11:46:36 Jan-06 20  LOADED BY: Richard2  REMOVAL TIME: 11:46:42 Jan-06 20  REMOVED BY: Richard2  MAX STORAGE: 168 HOURS  OOC EXPIRES: 14:46:52 Jan-06 20</p> </div>	<div data-bbox="823 465 1139 674" style="border: 1px solid black; border-radius: 15px; padding: 10px;"> <p><b>CABINET CLEAN RECORD</b>  Cabinet: ROTASCOPE 1  Date: 08:07:52 Jan-06 20  User: RICHARD    www.smartlinemachinery.com</p> </div>
Storage Label	Power Outage Record
<div data-bbox="248 824 555 1032" style="border: 1px solid black; border-radius: 15px; padding: 10px;"> <p><b>SCOPE STORAGE RECORD</b>  SCOPE TYPE: ENDOSCOPE  SCOPE NAME: scope 4  LOADED TO: ROTASCOPE 1:1  LOADED TIME: 11:46:58 Jan-06 20  LOADED BY: Door TAG  REMOVAL TIME: 11:47:09 Jan-06 20  REMOVED BY: Richard2  STORED FOR: 0.0 HOURS  OOC EXPIRES: 14:46:52 Jan-06 20</p> </div>	<div data-bbox="823 824 1139 1032" style="border: 1px solid black; border-radius: 15px; padding: 10px;"> <p><b>POWER OUTAGE RECORD</b>  CABINET: TestCab  TIME OFF: 12:56:22 Aug-03 21  TIME ON: 13:13:02 Aug-03 21  OoC TIME LOST: 0.3 HOURS  QTY SCOPES: 3</p> </div>
Incorrect Scope Removal	
<div data-bbox="248 1176 555 1384" style="border: 1px solid black; border-radius: 15px; padding: 10px;"> <p><b>INCORRECT SCOPE REMOVAL</b>  SCOPE TYPE: ENDOSCOPE  SCOPE NAME: scope 4  AER / WASHER: AER 1  WASHED AT: 14:46:58 Dec-16 19  AER OPERATOR: RICHARD  STORED IN:  REMOVAL TIME: _____ SIGN: _____  www.smartlinemachinery.com</p> </div>	
Environmental Alarm Labels	
<div data-bbox="248 1538 555 1747" style="border: 1px solid black; border-radius: 15px; padding: 10px;"> <p><b>ENVIRONMENTAL RECORD</b>  ROTASCOPE 1 13:11:41 Dec-17 19  <b>VACUUM ALARM 1051.18</b>  FRONT_DOOR OK: 0.00  REAR_DOOR OK: 0.00  HUMIDITY OK: 49.86  PRESSURE OK: 0.09  CAB_TEMP OK: 27.69  SAB_TEMP OK: 20.74  www.smartlinemachinery.com</p> </div>	

## 2.12 SmartStation Overview



The SmartStation is a universal device which is a combination of a Linux Controller, Touch Screen, and a Barcode Scanner with a Printer to produce sticker labels for reporting. The Barcode Scanner Handpiece and Charging Dock for the Barcode Scanner Handpiece is located here. The SmartStation connects to the Cabinet network via ethernet cable or via Wi-Fi. The inbuilt Speaker is used for audio and spoken prompts and the printer is used to deliver system warnings, and various printed stickers for different reported functions.

The SmartStation is used to:

- AER - Load/Unload AER - Scan Operator Barcode, Scope Barcode, AER Chamber Barcode to load the scope into the AER Washer
- Reprocessing area – Scan Scope Barcode and print scope status at any location to validate the status of the scope
- Used to print Error or Warning labels for reporting system status
- Multiple SmartStations may be added to the system to make scanning and or system or error reporting convenient in each area
- Printer Sticker roll ID is Smartline Medical *Part No 46.L4062-40 Label Roll – 40x62mm – 800 Labels per Roll (40mm Core)*

## 2.12.1 The SmartStation Touch Screen

SmartStation – Touchscreen Display



The Touch Screen display shows the station and application details, and may be set up differently depending on the configuration of your site

This intuitive device with Touch Screen may be used in conjunction with the Barcode Scanner to scan Operator ID, Scope ID and various function Barcodes

## 2.12.2 Operation of the SmartStation located at the AER Scope Washer



To ensure that a scope is correctly processed before storage, the SmartStation and Barcode Scanner are used to identify:

1. AER Chamber Barcodes  Eg Washer 1, Chamber 2

2. Operator ID Barcode  Staff Name Badge

3. Scope ID Barcode  Scope Barcode located on the Scope Handpiece

4. Time and Date  Is added by the system to the scanned data

The scope is identified as **Processed** or **Cleaned**

NOTE : The Scope Cleaning Process should have occurred in alignment with Scope manufacturer and AER manufacturer instructions for use (IFU), and in an “Approved Endoscope Reprocessing Cycle”, as per the hospital guidelines in your region.

AER Chamber Barcode Labels are used to identify each AER Washer and each Washer Chamber as a unique identifier.

The AER Chamber Barcode Labels are set up at installation by the Authorised Distributor.

AER Chamber Barcode Labels are fixed to each AER Chamber to identify specifically which washer and washer chamber that the scope is processed through, along with Operator ID, Scope ID and Time/Date.

NOTE: If an AER is removed for service or replaced by a new AER, then please contact your Sales Representative to get new AER Chamber Identification Barcode Stickers fitted to the new AER

Additional spare Washer Plaque Barcode Stickers are supplied in each Communication Kit – or an Authorised Distributor for additional stickers if needed



SCOPE ID BARCODE STICKERS are supplied upon installation and additional Scope ID Barcodes are available from an Authorised Distributor

Typically, the SCOPE ID BARCODE STICKER is located on the Endoscope Handpiece as indicated in this diagram

The Barcode should be easily visible so that scanning process can occur

The Barcode Sticker has no effect on the use or decontamination of the scope











The barcode may be easily removed if the scope is decommissioned

*Image above shows the supplied Scope ID Barcode fitted to a typical Endoscope Handpiece in a location that makes scanning the Scope ID Barcode easy*

## 2.12.2.1 The process of scanning a scope Through an AER Washer










### 2.12.2.2 Loading a scope IN to an AER Washer

1.		Scan Operator ID Barcode (Staff ID Badge) - “Audio Tone” “Click”	
2.		Scan Scope ID Barcode  (Scope Id Barcode Sticker. Typically located on Scope Handpiece) “Audio Tone” “Click”	
3.		<p>OPTIONAL - Long Storage is the Default Setting (usually 31 Days) – This may vary in your region – an Authorised Distributor will establish these times when your site is first set up.</p> <p>The Operator may select to scan either LONG STORAGE or SHORT STORAGE Time Barcode when Unloading the AER– NOTE If Long Storage is required (most usual) then this step may be omitted. i.e. Use only steps 1,2,4 – see notes about Long Storage and Short Storage under <b>Barcodes - Long Storage</b> – in the Definitions Section of this manual. Scanning toggles the long/short function.</p> <div style="display: flex; justify-content: center; align-items: center;"> <div style="border: 1px solid black; padding: 5px; margin: 5px;">  </div> <div style="border: 1px solid black; padding: 5px; margin: 5px;">  </div> </div> <p>Short and Long Barcode Labels are located on the SmartStation for determining if a Short Storage time is to be activated – usually sites elect Long storage (Maximum Storage Time for scopes) - unless the AER has a special short wash function. See Authorised Distributor.</p>	
4.		Scan Barcode AER’s Washer Plaque (IN)  A Barcode Sticker is located on the AER Washer Chamber  “Audio Tone” “Click” – <b>LOAD SCOPE into AER</b>	



### 2.12.2.3 Unloading a scope OUT of an AER Washer (When wash cycle is complete)

1.		Scan Operator ID Barcode (Staff ID Badge) - "Audio Tone" "Click"	
2.		Scan Scope ID Barcode (Scope ID Barcode Sticker – located on Scope Handpiece) "Audio Tone" "Click"	
3.		Scan Barcode AER SmartStation Washer Chamber ID  (A Barcode Sticker is Located on the AER Washer Chamber) "Audio Tone" "Click" – <b>REMOVE SCOPE from AER</b>	
4.		Collect <b>Scope Wash Record Sticker</b> from Printer located under the SmartStation	

#### IMPORTANT NOTE:

**IN** - Scanning scopes through the AER wash cycle creates a digital record for each scope wash cycle. The record identifies who loaded the scope IN to the AER, and which AER chamber the scope is to be washed in, along with time and date and operator details when loading.

**OUT** - When scanning a scope OUT of a washer, a digital record identifies who unloaded the scope from the AER and which AER chamber the scope was washed in, along with time / date and operator details when unloading. A Scope Wash Record Sticker is printed.

**IMPORTANT** -Operators must make a Critical Decision upon UNLOADING.

#### The Operator must:

1. Confirm that the selected AER cycle was completed successfully – By scanning a scope out of the AER the Operator takes responsibility for confirming the success of the wash cycle – staff should be reminded of this responsibility in regular staff training
2. The operator must select if the AER cycle is a Special Function Cycle and may result in a **Short Storage Time** – if the cycle is Short Storage, then the Short Storage Barcode should be swiped – see table above – the Short Storage function may be used in some regions, if an AER wash cycle omits alcohol flush for example – see your Authorised Distributor for help about regional regulations – many sites will never use this step.



### 2.12.3 Communication Kit (Part # COMMUNICATION KIT)



*Communications Kit Bag*

The Communications Kit is an accessory kit. When a Communications Kit is supplied it will be configured and installed by the installation team

#### **The Communication Kit contains:**

- Laptop Computer
- Computer Bag
- Laptop Charger
- 16Gb USB Stick Flash Drive
- Operator Tag/s
- Wi-Fi Dongle
- Extra Washer Plaque Barcodes (In/Out)
- Extra Staff ID Barcodes
- Extra Scope ID Barcodes
- The Laptop has the **Scope Manager Software** installed

If a Communications Kit is purchased, the Laptop Computer will be set up at installation – the laptop has Wi-Fi connectivity to the Cabinets and SmartStations

The laptop can be used to:

- Set up Staff ID Barcodes
- Set up Scope ID Barcodes
- Set up new Washer ID Barcodes
- View Cabinet Status
- Assist with Remote Login Support Service

Additional training will be provided at install

## 2.13 Scope Manager Software – Overview



**Scope Manager Software:** is loaded onto the Communications Kit Laptop Computer or an agreed Hospital Computer Terminal.

**Scope Manager Software** is used to manage

- SCOPE ID BARCODES
- OPERATOR ID BARCODES

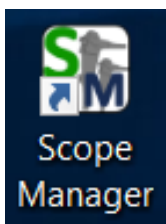
### 2.13.1 Installing Scope Manager Software

Usually, the software is installed by an Authorised Distributor upon set up of the site, however from time to time the software may need to be reinstalled due to PC replacement or reconfiguration or as below:

1. Using the USB provided in the Communications Kit or from the Authorised Distributor, run the Scope\_Manager\_2\_1 Install Application

 Scope_Manager_2_1	3/08/2020 3:28 PM	Application	1,740 KB
---	-------------------	-------------	----------

2. Right Click and Run as Administrator
3. Install the Application and create a shortcut to the Desktop of the PC



When installed onto a PC the Scope Manager icon should be used to create a Desktop Shortcut

4. Double Click to Open Scope Manager Software

## 2.13.2 Using Scope Manager Software – Managing SCOPE ID BARCODES

Scope Manager SCOPE Screen Tab

Scope Manager 2.6

Master Cabinet Address  
192.168.0.10

SMARTLINE MEDICAL

SCOPE OPERATOR LOCATIONS

Scope ID 0000001001 RETRIEVE

Type ENDOSCOPE ENDOSCOPE

Description Description of the scope

Out of Cabinet Time 3 Hours

Max Storage Time 744 Hours

UPLOAD

This software is simple to use and will be frequently used to manage OPERATOR ID BARCODES and SCOPE ID BARCODES and Scope Location

1. Make sure the laptop is connected to the wifi network of the cabinet. The MASTER CABINET IP Address is Printed on the ROUTER (above or near the Scope Cabinets)
2. Click on Function Tab "SCOPE"
3. Find a spare "Scope ID Barcode Tag" – supplied with Laptop Kit
  - a. Note: If scopes already have a 10-digit barcode attached, this barcode can be used in place of adding a new Smartline barcode.
4. Type in the 4 digit Barcode Number into the Scope ID Box, preceded by 000000 as shown above
5. Select the Type of Scope from the Drop-Down menu E.g., GASTROSCOPE
6. If required adjust the "OOC" and "Max Storage" time in HOURS
7. Press **UPLOAD** UPLOAD to create the code into the system – the Scope will now be recognised at all Cabinets and SmartStations

NOTE - LOCATIONS – May be used to manage individual scopes into specific Storage Locations – See Training support person for assistance.

- NOTE - RETRIEVE Function is used for when you would like to see the pre-set parameters of an existing Scope barcode i.e. it will populate the fields with previously set details.

### 2.13.3 Using Scope Manager Software – Managing OPERATOR ID BARCODES

Scope Manager USER Screen Tab

Scope Manager 2.6

Master Cabinet Address  
192.168.0.10

SCOPE OPERATOR LOCATIONS

Operator ID 2864440002 RETRIEVE

Type USER USER

Name Bob Smith (Team Leader)

UPLOAD

This software is simple to use and will be frequently used to manage OPERATOR ID BARCODES and SCOPE ID BARCODES and Scope Location

The simple layout of the screen allows you to select the function

- Make sure the laptop is connected to the wifi network of the cabinet. The MASTER CABINET IP Address is Printed on the ROUTER (above or near the Scope Cabinets)
- Click on Function Tab "OPERATOR"
- Find a spare "USER ID BARCODE" Operator Tag – supplied with Laptop Kit
- Type in the Operator Tag Barcode Number into the OPERATOR ID Box
- Select the Type of USER from the Drop-Down menu E.g., USER
- Press UPLOAD **UPLOAD** to create the code into the system – the Staff Operator ID will now be recognised at all Cabinets and SmartStations

### 3 Safety Instructions

- Cabinets MUST BE positioned on a stable, level floor.
- Cabinet power cable must be securely plugged into a standard GPO & switched On.
- Inspect door components of the equipment prior to use as well as daily – inspection to also be performed on rear door where fitted.
  - Inspect the door components i.e.: handle, hinges, and locking mechanism (where fitted) for functionality, wear and tear or damage.
  - Is the door easy to open and shut?
  - Are there any obstructions in front of, or near the door to prevent it from opening?
  - Do the cabinet interior lamps illuminate when the door is opened & extinguish when the door is closed?
- Inspect the silicone connection hoses & luer fittings for wear & tear or damage.
- Are the silicone connection hoses connected to the cabinet post luer fittings?
- Are the silicone connection hoses connected to the cleaning adaptors or scopes as per instruction diagrams?
- Are the instruction diagrams located within convenient view?
- Is the power cable securely plugged in & power turned On?
- Inspect all data system components power cables are securely plugged in & power is switched On.
- Inspect all data system components, accessories & connection cables for functionality, wear & tear or damage.
- Inspect the digital display for normal function.
- If any inspection fails, please advise your supervisor as soon as possible.

**The Cabinet Environmental Monitor measures and records the following cabinet conditions:**

- Cabinet Internal Chamber Temperature
- System Vacuum level
- Cabinet Humidity
- Cabinet Internal Pressure
- Routine Cleaning Status
- Power including Outages, Interlocking Doors and generates signal notifications to Hospital Alarm Monitor System
- Scope location and storage times
- OOC – Out of Cabinet Time Countdown – maximum of 180 minutes allowed for a scope to be outside of the Storage Cabinet after reprocessing. ie a scope should be dried within 3 hours.

The system automatically maintains a positive pressure within each cabinet. By having a positively pressured cabinet, external air (cleaning room) will inhibit flow into the cabinet.

All the Environmental Conditions are measured and recorded by the Data Management System as required to meet the EN16442 standards. During cabinet

operation, if an operational parameter exceeds a set operational value an Alarm or Warning may be triggered, and the following will occur:

- An automatically generated printout identifies the issue (where applicable)
- Screen display will turn red to highlight issues
- Cabinet lighting will change colour (each fault has an assigned colour)

## **⚠ WARNING**

**Read and understand this manual and its safety instructions before using this product. Failure to do so can result in serious injury or death.**

### **3.1 How to Use the Product Safely**

- Some staff may have difficulty reaching scopes when loading or unloading the cabinet, due to the height of the loaded scopes. It is advisable that an appropriate step stool be used. Consult with your local Occupational Health Officer to determine a safe work method for your site.

#### **3.1.1 Control screens, and electrical enclosures**

- Do not open and access the control units without specific training from the Authorised Distributor.

#### **3.1.2 Technical life span**

- Annual service and preventative maintenance are required
  - To ensure you get the best performance out of your Cabinets, it is an operational requirement to have a Maintenance Contract in place. These contracts are to be set up through the Maintenance Department. A Maintenance Contract is an annual service agreement covering replacement equipment e.g., filters and parts for the Integrated Air System IAS, and basic ongoing cabinet maintenance of cabinet fittings and fixtures.
- The viable lifecycle of the cabinet is 7 years from date of purchase

#### **3.1.3 PQ Performance Qualification**

- Annual Performance Qualification required. EN16442:2015 states in section E.2 and Annex D - Performance qualification and routine testing – must be performed

- AS/NZS4187:2014 Section 7.4 States: **Performance qualification shall be performed by the HSO.** PQ may be performed by suitable trained in-house personnel or a suitable experienced and qualified external contractor. PQ shall be undertaken in accordance with the applicable national or international standards.

**PQ shall be performed:**

- (a) Immediately after IQ (Install Qualification) and OQ (Operation Qualification) for newly installed or relocated equipment.
- (b) When repairs are made, or a service is changed that might adversely impact the quality of the RMD (see Clause 10.5).
- (c) When existing equipment is modified to deliver a new process.
- (d) Using RMDs that are representative of the range of RMDs identified as the most difficult to process that are in use in the HSO. Refer to clause 5.2; and
- (e) When introducing new or modified RMD, packaging or loading configurations unless equivalence to a previously qualified reference load, RMD/product family, packaging or loading pattern has been demonstrated.

**Requalification of the process shall be performed annually. Refer Clause 10.4.**

Smartline Medical does offer a performance Qualification Service for the RotaScope Cabinets in line with the requirements of AS/NZS4187:2014 and BS EN16442:2015.

Please email [sales@smartlinemachinery.com](mailto:sales@smartlinemachinery.com) or call +61 7 5478 9977 for a PQ quote or contact your Authorised Distributor.

See Also – IQ (Installation Qualification) and OQ (Operation Qualification) – performed upon installation by the Authorised Distributor

IQ-OQ-PQ testing methods are used to ensure that that after install or relocation of your cabinets, that the install environment, set up, and performance is configured to meet the required standards for drying and storage of your endoscopes.

This is a requirement.

### **3.1.4 Safety information related to the intended use and reasonably foreseeable misuse.**

#### **3.1.4.1 Condition of the Endoscope**

Verification is required that all channels allow the passage of air before the device is loaded into the storage cabinet when a scope has been cleaned and disinfected using a manual cleaning procedure. The internal channels of the endoscope are to undergo an aeration test (bubble test) as per manufactures instructions.

In the case where the endoscope is cleaned and disinfected using a validated processing procedure (washers compliant with EN ISO 15883-4:2009), this verification is included through the washer's channel monitoring; however, extensive air flushing (Purging) of all channels is recommended before placing the endoscope in the cabinet to purge any bulk water left inside endoscope channels from the washers.

NOTE: If you do not air purge the internal channels of the endoscopes after the washing/disinfection procedure, retained moisture could impact on the storage cabinet efficiency. Users are reminded that it is important to conform to manufacturer's recommendations and instructions.

Scopes should have channels blown dry with medical air from handpiece ports including biopsy channel and thumb ports for suction and air/water.

Verification is required that all channels allow the passage of air before the device is loaded into the storage cabinet.

Endoscopes should be transferred into storage/ drying cabinet as soon as possible after endoscope has completed all of it set cleaning phases. Take care to not touch any part of the endoscope on surfaces that may cause a cross contamination onto the endoscope.

NOTE: The electronic data system of the Cabinet counts the time taken from the removal of the scope from the washer to the time loaded into the cabinet. The data system deducts this "loading time" from the three-hour factory set 3 hour "Out Of Cabinet Time" (OOC) and displays the remaining time on the Control Screen for each loaded scope.

#### **3.1.4.2 In case of power failure**

Restore power as quickly as possible to the endoscope storage cabinet or transfer endoscopes to a fully operational cabinet.

NOTE: The electronic data system of the Cabinet will count every minute that the endoscope is stored without power as a minute of "Out of Cabinet Time" (OOC). Each endoscope has only 180 minutes of Out of Cabinet time per cleaning cycle. If endoscopes are stored without power for a period that excess the Out of Cabinet time, endoscopes will have to go through the cleaning cycle again in full to be reprocessed prior to use.



### 3.1.5 Personal Protective Equipment

Standard hospital PPE (scrubs or gown, masks and gloves) should be used when interacting with the internals of this cabinet to reduce any chance of contamination. Personal hygiene (hand washing or use of gloves) must be considered when interacting with the inside of the cabinet.

### 3.1.6 Product limitations and restrictions

Endoscope cabinets are for storage and or drying of endoscopes, including internal channels, in a controlled environment. The controlled environment ensures that there is no deterioration of microbiological quality of the endoscope.

The drying function supplements drying after manual or automated disinfection. The storage cabinet allows for safe delivery of Endoscopes for an extended period after reprocessing.

**Note 1** – Drying Cabinets are intended to dry and store thermolabile flexible endoscopes – however the endoscopes should be free from bulk liquid saturation which may affect the anticipated drying rate of the endoscope when loaded into the cabinet. Drying cycles of AER (Automatic Endoscope Repressors), should be set to allow for the removal of bulk liquids where possible, and or, Endoscopes should be purged by manual purging to remove bulk liquid before loading into the drying cabinet.

Endoscopes that have undergone manual cleaning processes only should be purged of bulk liquids before loading into the drying cabinets.

**Note 2** – Strong recommendation is given to verify the microbiological quality of the endoscopes intended to be stored in the cabinet before installation of the cabinet by ensuring scopes have followed the recommended manufacturers decontamination guidelines

**Note 3** – Storage cabinets are not designed to clean or disinfect endoscopes and any contaminated endoscopes may still be contaminated after the storage.

**Note 4** – Storage Cabinets housing thermolabile endoscopes are NOT considered medical devices

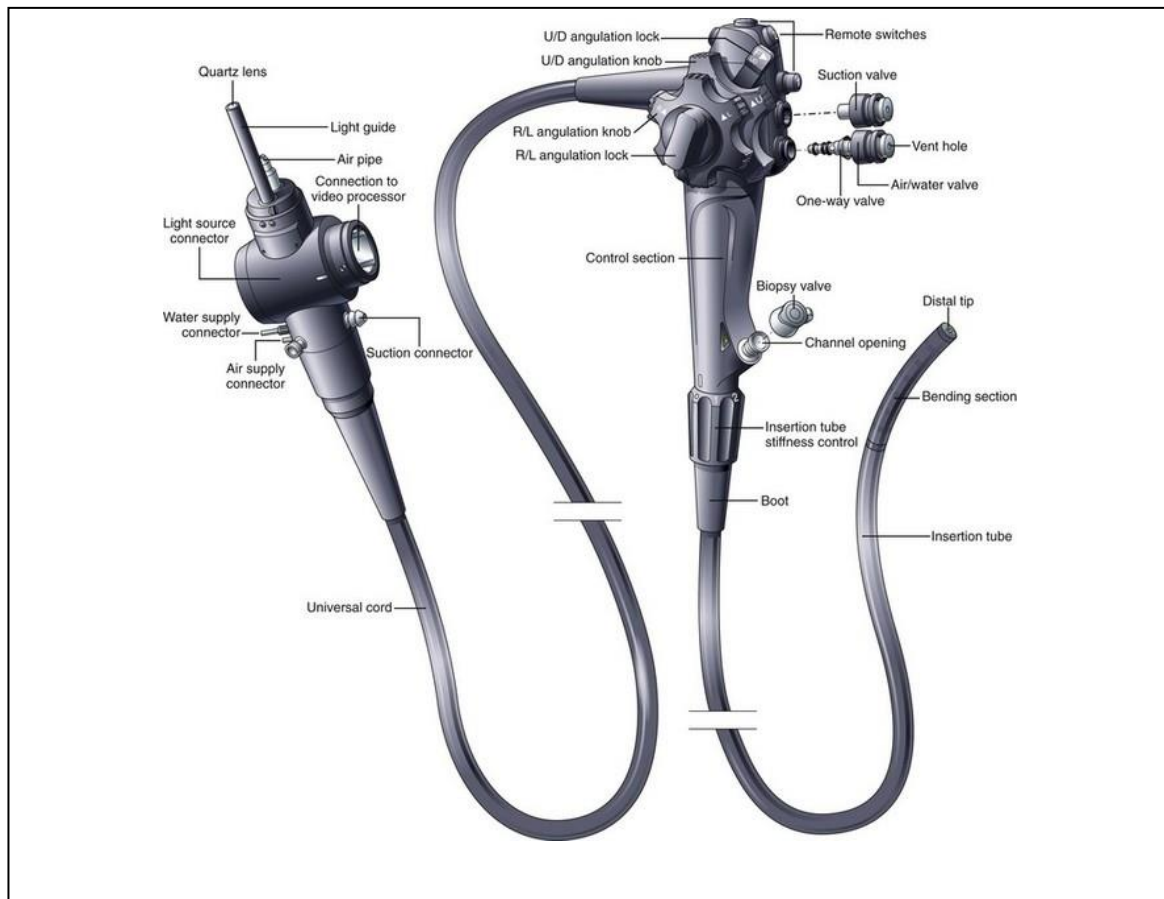
The aim of drying endoscopes after suitable reprocessing, is to remove moisture from the scope and channels in under three hours, to prevent microbiological growth.

Installation/Service safety – Installation and Service should be conducted by Authorised Distributors only. Cabinets that have been installed, serviced or altered by non-authorised technicians will not be deemed to be fit for purpose, and will not be covered by warranty.

### 3.1.7 Maintenance safety information

To ensure you get the best performance out of your cabinet, it is an operational requirement to have a Maintenance Contract in place. Maintenance Contracts are to be set up through the Maintenance Department. A Maintenance Contract is an annual service agreement covering servicing, and or, replacement of equipment e.g., filters and parts. Maintenance is to be conducted by Authorised Distributors only.

### 3.2 General Anatomy of an Endoscope



The image above outlines the various parts of a typical thermolabile flexible endoscope

Whilst the design and functions of endoscopes may vary – the Drying Principles remain the same across various scope families and brands.

The cabinet is designed to Store and Dry various approved endoscopes, externally and internally via connection to the drying cabinet air system using **Scope Connector Hose Kits**.

### 3.3 Scope Connector Hose Kits

Scope Connector Hose Kits are separately purchased for each scope that is to be loaded into the cabinets.

**Colour Coded Scope Connector Hose Kit Examples:**

*Pole Manifold*

**Auxilliary Connector Hose**

**Suction Connection Hose**  
Leave This End Open

**Biopsy Valve Hose**

**Air Water Connection Hose**

**Bronchoscope Biopsy Valve Hose**

**Bronchoscope Port Hose**

**Hose colour is matched to similar connection port identification stickers**

A Luer Lock fitting at one end of the connecting hose, terminates to the relevant Luer Nipple on the cabinet Vacuum Manifold Block – these fittings require just a quarter turn to securely fit the hose onto the cabinet air system.

On the other end of each hose is a fitting that will suit termination onto the relevant scope channel port.

The **Scope Connector Hose Kits** are used to connect different Brand Endoscopes and different types of Endoscopes to the drying system.

Each different Endoscope has specific Endoscope Channels (Lumens) which perform varied functions during endoscope use. To dry each of these channels, hoses with specialized fittings are tested to ensure correct fit and drying performance, for each approved scope.

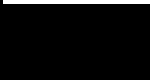







Each hose is colour coded and matched with the correct port fittings so that the scope channels can be connected to the scope and system correctly.

A colour coded sticker on the scope cabinet Vacuum Manifold Blocks is used to visually match the coloured hose with the coloured sticker.

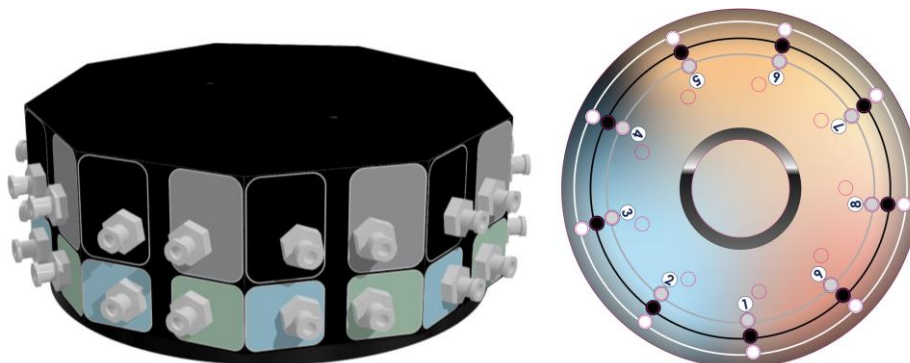
### 3.3.1 Scope Connector Hose Kits - Colour Coding:

#### Scope Connector Hose Kit - Colour Coding:

The manifold is fitted with a colour coded sticker to match with coloured hoses

Name/Location	Port No On sticker	Hose ID mm	Hose OD mm	Colour	Sample
<b>Handpiece</b>					
Auxiliary	1	4.0	6.5	BLACK	
Biopsy	2	4.0	6.5	WHITE	
Spare	3	4.0	6.5	LT GREY	
<b>Umbilical</b>					
Suction	4	5.8	9.0	DK GREY	
Air	5	4.0	6.5	LT GREEN	
Water	6	4.0	6.5	LT BLUE	
Auxiliary / Jet	7	4.0	6.5	BLACK	
Lower Air Pipe	-	3.2	6.4	CLEAR	

NOTE: See your Authorised Distributor for detailed selection of **Scope Connector Hose Kits** to suit your specific Endoscope connection to the cabinet air system



*Match Hose Colour with Sticker colour on Centre Pole Manifold or Top Disk Stickers*

### 3.3.2 Scope Connector Hose Kits – Cleaning IFU

#### RECOMMENDED STEPS for Manual Cleaning Scope Connector Hose Kits:

##### (IFU) Instructions For Use



1. Prepare appropriate amount of cleaning solution (biofilm remover or enzymatic detergent solution) in a sink, as per the chemical manufacturer's instructions.
2. Remove hose/s to be cleaned from cabinet and place in sink.
3. Make sure the hoses remain fully immersed throughout the cleaning process.
4. Use a small soft brush to clean the connectors at each end of the hose.
5. Wipe exterior surfaces of hoses with a nonabrasive and lint free cloth.
6. Check that all visible debris have been removed.
7. Optionally, attach hoses to a **Washer Rack Hose Connection Kit**.
8. Use a syringe to push fresh solution through hoses and then flush out. Repeat a minimum of two more times, do not flush out on last action.
9. Achieve contact time with hoses submerged for the appropriate timeframe outlined in the chosen cleaning solution IFU.
10. Purge cleaning solution from channels while fully immersed.
11. Repeat steps 7-10 until all hoses have been flushed and purged.
12. Discard cleaning solution.
13. Use a syringe to push fresh water through hoses to remove all cleaning solution.
14. Thoroughly wash exterior of all hoses with fresh water to remove all traces of cleaning solution.
15. Remove hoses from sink and hold in a vertical position to allow water to drain out. Use a syringe or medical air supplied air gun to purge any remaining water from the inside of the hose.
  - a. Dry in a drying cabinet where possible.
  - b. Dry with medical grade air where possible.
16. Remove hoses from the **Washer Rack Hose Connection Kit**.

Hang hoses back inside endoscope cabinet connected to forced air for additional drying.

*This page may be printed and displayed at your wash area*


**Scope Connector Hose Kits** and ESC connectors (Endoscope Connectors) are to be disinfected every 7 days or upon disconnection from a valid stored endoscope if time since last disinfection exceeds 7 days. Hoses and ESC connectors should be inspected for any damage or degradation of the items that would diminish the items' ability to perform at its full capacity. Before attaching the hose kit to the scopes or the cabinet we recommend manually disinfecting the hoses and lines. Alternatively, the hose kits may be autoclaved as per your local guidelines.

### 3.3.3 Selecting Scope Connector Hose Kits, for your fleet of Scopes

There are many Brands and Models of Endoscopes available. Each scope has specific connection points that need to be matched with approved connection fittings. Approved fittings ensure that air will successfully pass through the scope to dry the scope in the recommended time in the cabinet.

When sharing the Endoscope Model Number, it is very important to exactly capture the precise details including Capital and lower-case letters, hyphens, numbers and spacings – e.g. EC-760ZP-V/L Examples of approved scope kits can be seen below – As there are so many, they are not listed individually in this manual – please refer to the **ApprovedScopeList.pdf** and refer to your local Distributor to obtain full details of each required Scope Connection Hose Kit.

#### Examples below of Scope Connection and Approved Scope detail sheets



+61 5478 9977    www.smartlinemedical.com  
55 Cordwell Road, Yandina, Queensland 4561 AUSTRALIA  
ABN 34 119 209 611

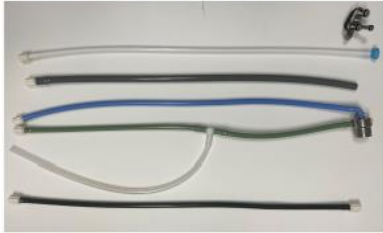
---

**Instructions for Use:**  
**90.KIT-FU-001 - Fuji 700 Series Kit**

**Kit Includes:**

Item Code	Item Description	Unit	Qty
90.AW-FU-001	Fuji Air Water Connector Hose (Blue/Green)	Each	1
90.BIO-001	Universal Biopsy Valve Hose (White)	Each	1
90.CS-FU-002	Fuji 700 Series Channel Separator	Each	1
90.SUC-001	Universal Suction Connection Hose (Grey)	Each	1
90.UNI-002	Universal Luer Connection Hose (Black)	Each	1

**Included items:**



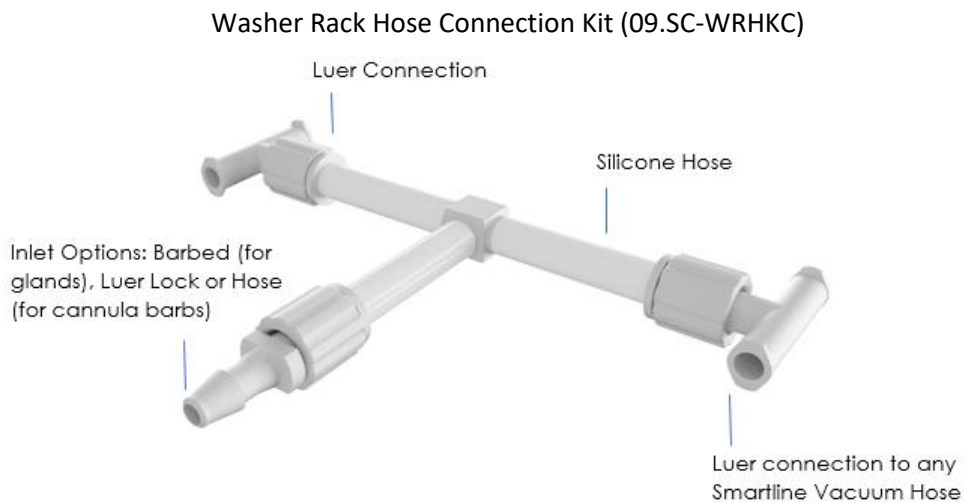
**Suits Scopes:**

EC-760R-V/L; EC-760ZP-V/L; EC-760ZP-V/L; EC-740TL; EG-780Z; EG-760CT; EG-760R; EG-760Z; EG-760CT; EC-720R/L; EC-720R/L; EC-720R/L; EC-720R/M; EC-730RV/L; EC-760R-V/M; EC-760R-V/L; EC-760P-V/L; EC-760P-V/M; EC-760ZP-V/M; EC-760Z-V/M; EC-760Z-V/L; EC-760S-V/L; EC-740T/M;

For a copy of the **ApprovedScopeList.pdf** – please email – [sales@smartlinemedical.com](mailto:sales@smartlinemedical.com) for the latest version or contact your local Authorised Distributor

### 3.3.4 Washer Rack Hose Connection Kit (Optional)

A modular accessory is available, that can be utilised during an Automated Cleaning Process.



The **Washer Rack Hose Connection Kit** is an accessory used by the Central Sterilising Department in combination with some type of Automated Instrument Washer

The purpose of the Washer Rack Hose Connection Kit is to connect several hoses (Scope Connector Hose Kits) simultaneously to reduce reprocessing costs

The Inlet is connected to an Automatic Washer – the 4 Luer connections are connected to cabinet Scope Connector Hose Kits.

Note: Scope Connector Hose Kits, join Endoscopes to the RotaScope Drying Cabinet airflow system



High-level disinfection of each Scope Connector Hose Kit, should be undertaken weekly (during the Cabinet Cleaning Cycle).

Cleaning may be Manual or Automated and can also be autoclaved to gain shelf life.

During Weekly Cleaning, please reference the Scope Connector Hose Kits Cleaning IFU above – some instructions may need to be modified where required, to suit the equipment available to the department.

#### 3.3.4.1 Approved Scope List

EN16442:2015 Standards requires that the cabinet manufacturer publishes an Approved Scope List. The most current ***ApprovedScopeList.pdf*** is available upon request via email [sales@smartlinemedical.com](mailto:sales@smartlinemedical.com)

### 3.4 Cleaning of Cabinets IFU (Instructions For Use)

In accordance with Standards EN16442:2015, the cabinet cleaning cycle frequency is stated by the manufacturer. Cabinets must be cleaned in no more than a seven-day repeated cycle.



**Blue = Clean Due**

The cabinet lighting will provide a visual warning when cleaning is due. The cabinet will illuminate in BLUE color lighting, 24 hours before the Clean Due expiry time.

A Clean Due notification is displayed on the Cabinet Clean Button located on the Main Screen of the Cabinet Control Screen. The Clean Due notification indicates the weekly cleaning Expiry Time. The cabinet should be cleaned within 24 hours (one day) of when the cabinet lighting has turned BLUE.

The Cabinet Cleaning Function can be reset at any time by Swiping a Staff Barcode ID Tag on the scanner located under the Cabinet Control Screen, then pressing the Cabinet Clean Button located on the Main Screen.

Cabinet interior & exterior surfaces to be cleaned using soft, clean cloths & non-abrasive cleaning/disinfecting products that do not contain ammonia or alcohol. Any abrasive cleaning product or cloth/scourers will permanently mark the surface and should be avoided.

Do not allow electrical or electronic components, to become wet or splashed with water or other fluids. Any fluids issuing from recently loaded scopes should immediately be wiped up.

Note: Liquids issued out of an endoscope at time of loading into the drying cabinet, usually indicates that the scope has not been suitably purged or that the drying cycle of the washer has not been set to a suitable run time.

Note: Frequently loading very wet scopes into drying cabinets may result in increased bioburden forming on scope cabinet surfaces and is to be avoided.

Scope handling, preparation and loading techniques should be explored by HSO (Health Service Organisations) to determine a best practice formula that suits the equipment and practices in the decontamination department. Please consult with an Authorised Distributor for guidance.

*This page may be printed and displayed near the cabinets as a weekly cleaning guide*



**3.4.1 Internal Surfaces Cabinet Cleaning IFU (Instructions For Use)**

Cleaning of the RotaScope cabinet should be carried out in accordance with local guidelines in less than 7-day intervals.

- Remove all scopes from the cabinets and store appropriately
- Press the REMOVE ALL SCOPES BUTTON located on the Control Screen of Cabinet Controller – this will allow all scopes to be removed for cleaning at one time without having to scan each scope out individually
- Clean from top to bottom, and hardest to reach section to easiest to reach section of the cabinet.
- The recommended cleaning technique is to wipe all interior surfaces with a non-alcoholic disinfectant wipe.
- Cleaning the human touch-points, where operators frequently touch, is particularly important. Methodical manual cleaning of these points should occur.
- Hang Hooks should be frequently cleaned
- Any fluids inadvertently spilled or dripped onto the cabinet are to be wiped up immediately using a soft lint free cloth
- When the cabinet is clean – replace each scope back into the cabinet by scanning your Operator ID Barcode Tag then the Scope ID Barcode (Follow the Loading a Scope Procedure as in this manual)

**NOTE** -Please do not use cleaners containing ammonia or alcohol or abrasive materials, as it may damage cabinet surfaces.

*This page may be printed and displayed near the cabinets as a weekly cleaning guide*

### 3.4.2 Cleaning External Surfaces

Cleaning external surfaces:

Wipe down all surfaces with a mild detergent and soft lint free cloth

- Pay particular attention to high human touch-points such as door handles
- If the cabinet is located within an operating room – follow typical procedures for cleaning an operating room
- If the cabinet is located in a scope processing room – follow typical procedures for cleaning a scope processing room

**NOTE** -Please do not use cleaners containing ammonia or alcohol or abrasive materials, as it may damage cabinet surfaces.

**NOTE** – Detergent Wipes and or Disinfectant wipes may be used to clean the external surfaces of RotaScope cabinets


*This page may be printed and displayed near the cabinets as a weekly cleaning guide*

### 3.4.3 Safe Disposal

Test procedure to facilitate safe disposal of the device and related waste substances

- The Cabinets are manufactured using mostly acrylic plastics, stainless steel and ROHS approved electronic components. Most parts can be substantially recycled for care of the environment. However, the cabinets should be thoroughly cleaned before disposal, and consultation with local recycling parties should be undertaken in accordance with your environmental, infection control and recycling policy.

## 3.5 Terms and definitions used in this manual

Term	Meaning
<p>9V Battery</p> 	<p>A 9V Battery – Used to manually unlock cabinet doors in case of power failure – battery may be inserted into the battery compartment located under the Cabinet Control Screen on the cabinet door – firmly pressing the battery upwards will disengage the door lock electronically</p> <p>If the battery supplied has aged it may need to be replaced from time to time</p>
AER	Automated Endoscope Preprocessor (Automatic Scope Washer)
AER	Automatic Endoscope Reprocessor (Scope washer)
Air Intake Filter	<p>The air intake filter) is located in the IAS (Integrated Air System) Housing on top of the cabinet.</p> <p>The Air Intake Filter must be replaced annually by an Authorised Distributor at Annual Service</p>
Annual Service	<p>RotaScope Cabinets should be serviced by way of an annual service contract each year. The service should be performed by an Authorised Distributor. The service will include inspection, calibration if required, and includes the replacement of filters, pumps and is described in detail in the Annual Service Agreement.</p>
Approved Scopes	<p>See list of Approved endoscopes appendix – listing scopes approved as suitable to be dried and stored in RotaScope Cabinets</p> <p>See - <b>ApprovedScopeList.pdf</b></p>
Barcode - AER Chamber - SmartStation	<p>Barcode Stickers are produced upon install by the Install Team and affixed to each AER washer chamber – the Barcode identifies specifically the Washer ID, Name and Chamber Number – when Operator and Scope are scanned, the system records a unique wash cycle reference</p> <p>Scanning a scope out of the washer confirms that the wash cycle was complete and successful</p> <p>NOTE – this confirmation relies on the Operator acknowledging the success of the wash cycle – scanning the Operator ID Barcode and the Scope ID Barcode out of the washer records that the Operator is accepting the wash cycle success from that washer/chamber</p>
Barcode – Scope ID	<p>A barcode is printed for each endoscope – the barcode should be affixed to the endoscope on the handpiece and should be positioned for easy</p>

	<p>scanning when the scope is Loaded. The barcode will be seen by the system and identifies the Scope Name (E.g. New Scope), ID Number (E.g. Serial number), and Type (E.g. Colonoscope) and number of Scope Channels (E.g.5 Channels)</p> <p>The barcode is recorded against a process Eg New Scope Loaded into Cabinet One, Position 3 at 10:42am on 15<sup>th</sup> May 2021 by Mary Smith – to set up a new Scope ID Barcode – see section – Managing Scope ID Barcodes</p>
Barcode - Short Storage	<p>The SHORT STORAGE Barcode sticker is located at the SmartStation by the AER Washer – The SHORT STORAGE Barcode is scanned as part of loading the scope into the washer to select SHORT STORAGE time of the Scope if your region has guidelines that accept a partial or short AER wash cycle</p> <p>(The SHORT STORAGE time is the specific storage time allowed for that scope and is determined by the setup of the Scope ID Barcode when the Scope ID is setup the first time)</p> <p>To select the SHORT STORAGE Time, using the Barcode Scanner, swipe</p> <ul style="list-style-type: none"> <li>• SHORT STORAGE Time Barcode Sticker</li> <li>• Operator ID Barcode</li> <li>• Scope ID Barcode</li> <li>• AER Chamber Barcode Sticker (4 Scans)</li> </ul>
Barcode – Short Storage or Long Storage	<p>The LONG STORAGE Barcode Sticker is located at the SmartStation by the AER Washer – The LONG STORAGE Barcode is scanned as part of loading the scope into the washer to select LONG STORAGE time of the Scope</p> <p>The Long Storage Time is the maximum storage time allowed for that scope and is determined by the setup of the Scope ID Barcode when the Scope ID is setup the first time – In some regions a partial wash of the scope is acceptable i.e. a shorter wash cycle at the AER – in this case the Short Storage function is selected – see Barcode – SHORT STORAGE</p> <p>The LONG STORAGE Time (Maximum Storage Time) is the default setting – usually scopes are stored with Maximum Storage Time (Up to 31 Days – may vary in different Countries)</p> <p>To select the LONG STORAGE Time, using the Barcode Scanner, scan</p> <ul style="list-style-type: none"> <li>• LONG STORAGE Time Barcode Sticker</li> <li>• Operator ID Barcode</li> <li>• Scope ID Barcode</li> <li>• AER Chamber Barcode Sticker (4 Scans)</li> </ul>


Barcode – Staff ID	<p>A barcode is printed for each staff member – the barcode should be affixed to a staff badge or lanyard – the barcode will be seen by the system and identifies the staff name when recorded against a process – to set up a new staff barcode – see section – “<i>Setting up a Staff Barcode</i>”</p>
Cabinet Control Screen	<p>Also called “Door Blister” – This control screen is located at eye level on the front and rear door of the cabinet if fitted.</p> <p>This device is a touch screen control and display interface, with speaker for audio prompts and a barcode scanner for staff, scope identification – The Cabinet Control Screen is housed in an acrylic housing with a metal curved façade. The screen displays cabinet environmental information, quick visual status of each scope stored including time stored and OOC time “Out Of Cabinet” time, if a scope was removed</p> <p>The other detail screens provide technical details about each scope, remaining storage time and Cabinet Cleaning Due Date – other screens display details about cabinet pressure, pump temperature and speeds and cabinet humidity and temperature.</p> <p>The main screen is usually all an operator needs to see - including scope details and current status eg drying or dry. Clear simple icons denote scope drying status and remaining storage time – Selecting a scope with the least remaining time allows efficiency in reducing scope reprocessing by use of “Oldest Stored Scope First”</p>
Cabinet Pressure	<p>The positive pressure inside the cabinet – this should be greater than the adjacent rooms ensuring positive pressured HEPA Filtered Air is always purging out of the cabinet preventing room air from occupying the cabinet</p> <p>The Cabinet pressure can be viewed on the Main Screen of the Cabinet Control Screen located on the cabinet door/s</p> <p>The cabinet air is exchanged approximately 12 times per hour to remove moisture from the cabinet environment and maintain a positive pressure of around &gt; 25Pa pressure</p>
Channels	<p>Also called Endoscope Lumens, Scope Ports, E.g Biopsy, Auxiliary, Air channel, Water channel, Balloon channel, Suction channel – spare/other – to connect to a scope channel colour coded hoses with specialized fitting are used and connect to the scope ports – see Scope Ports</p>

<p>Compliance</p>	<p>RotaScope Cabinets are manufactured and set up in accordance with EN16442:2015 Standards, however local endoscopy or sterile area guidelines may provide additional recommendations or limitations on use of drying cabinets. Please refer to the legislative directives of your region in addition to the EN16442:2015 Standards.</p> <p>Various electrical compliance and safety tests have also been conducted on RotaScope Cabinets and can be seen in the Compliances section of this IFU</p>
<p>Data Management System</p>	<p>Describes the computerised management system that manages: the displays, stored information, various cabinet sensors and attached devices, barcode information, and other inputs. The data management system manages the system performance, collects data about the operator, scope, location, storage duration, OOC, and other functions. The Data Management System creates Visual and Audible notifications of performance and warnings.</p>
<p>Door Lock</p>	<p>Electronic Door locks are located in the middle of each door behind the door handle – the locks are controlled by swiping a staff barcode (below the Cabinet Control Screen) to unlock.</p> <p>If configured as a “Pass-Through” cabinet with a rear door fitted, the door locks are configured as “Interlocking” allowing only one door to be opened at a time.</p> <p>In case of a power failure the door can be unlocked by inserting a 9V Battery into the battery compartment located under the Cabinet Control Screen – pressing the battery firmly upwards will power the door lock to release the door.</p> <p>In case of a lock failure the cabinet door can be unlocked by removing the small lock retaining screws located on the outside edge of the door handle. The door can be opened for access to the cabinet and the door lock can be unplugged and replaced.</p> <p>Alternatively, if a door lock fails, door lock pins are located on the door frame of the cabinet and can be unscrewed by access through the opposite door of a Pass-Through cabinet or by removing the rear closing panel if fitted on a single door cabinet.</p>
<p>DRY</p>	<p>RotaScope Classic Cabinets are manufactured and tested in accordance with EN16442 Standards and are validated to store endoscopes for a duration of up to 31 Days</p>

	<p>Allowable Storage Time may also be dependent on local guidelines and should be considered by your HSO policy.</p> <p>The recognised description of a DRY endoscope has previously been cited in EN16442:2015 section 6.4.3.1 which states that “to test that a scope has been dried, Compressed air shall be passed through the scope channels and the use of Litmus paper should indicate the evidence of residual water”.</p> <p>If scopes are suitably washed, checked, purged and loaded into the RotaScope then residual moisture should never appear on litmus paper when tested in accordance with EN16442 methods. If scopes fail to dry in under three hours in a RotaScope Cabinet, then this should be explored with an Authorised Distributor.</p>
EN16442	European / British Standard - EN16442:2015 - Controlled environment storage cabinet for processed thermolabile endoscopes
GPO	General Power Outlet (Mains Power Point 110/240V)
Hard Reset	<p>A Hard Reset may be done by using the Hard Reset Button which is located at the top of the cabinet behind the top façade. The hard reset button restarts the Linux Computer System and normal operating parameters. The cabinet will reset and restart after pressing the Hard Reset Button – this Hard reset is usually performed when prompted by a support technician in case of a default</p> <p>A Hard Reset will not reset storage times or lose operational data</p>
HEPA Filter	<p>A HEPA Filter (High Efficiency Particulate Absorbing) is located in the IAS (Integrated Air System) housing on top of the cabinet. The HEPA Filter is Class 14 i.e. 99.99% , 0.3um (0.3 Micron)</p> <p>The HEPA Filter must be replaced annually by an Authorised Distributor at Annual Service</p>
Hose Connection Kits	<p>Each stored endoscope needs to be connected to the cabinet airflow system, so that the scope channels (Lumens) are dried internally</p> <p>RotaScope Cabinets require a Hose Connection Kit to be purchased for each type of scope stored</p> <p>The colour coded hoses have a Luer fitting on one end to terminate onto the luer fittings located on the Manifold Block which is on the Centre Pole</p>

















Humidity - Cabinet	The humidity inside the Scope Cabinet – this can be viewed on the Main Screen of the Cabinet Control Screen located on the cabinet door/s
IFU	Instruction For Use
IQ-OQ-PQ	<p>Install Qualification – IQ – asks if the install environment is suitable (Room, position, connection)</p> <p>Operation Qualification – OQ – asks if the RotaScope is set up correctly to suit the department, users, and scope list</p> <p>Performance Qualification – PQ – is the biological test routine signifying that the use, cleaning and operation of the cabinet is delivering correct outcomes over time</p> <p>Described in EN1644:2015 and AS4187 Standards</p>
Magenta	Colour also referred to as PURPLE – signifying a power outage has occurred – the cabinet lighting turns purple after a power outage, when the power resumes
Manifold	The Manifold also called the “Vacuum Connection Block” is located on the Centre Pole – The Manifold features Luer connection nipples that connect scope channels via Colour Coded Connection Hoses to the Vacuum air flow for drying the scope channels (Lumens) Match hose colour to the coloured stickers to ensure correct connection
OOC	<p>“Out of Cabinet” Time – Displayed on Main Cabinet Control Screen – OOC is the recorded countdown time that a scope is not in the cabinet – OOC is a total of 3 hours (180 Minutes) – OOC starts upon swiping the barcode of the scope upon removal from the AER (Washer) – count down stops when the scope is loaded into the cabinet – OOC Countdown resumes when a scope is taken out of a cabinet to be moved or used, and if the scope is returned to the cabinet the countdown is deducted from remaining OOC time and displayed on the Main Cabinet Control Screen.</p> <p>The aim of OOC Time is to ensure that scopes are dried within three hours of decontamination and OOC manages the exposure of clean scopes to uncontrolled environments</p>
Pass Through	RotaScope Cabinets may be configured with an optional rear door, enabling the cabinet to be installed in-wall, allowing scopes to be loaded on one side (Front door), stored, and unloaded on the opposite side (Rear Door) – for improved work flow and infection control

<p>Power Outage</p>	<p>From time-to-time, Electrical Power Supply failure may occur in a hospital – The Scope Cabinet will signify a Power Outage via the cabinet lighting turning PURPLE in colour.</p> <p>The use of the Alarm Acknowledge Button located on the control screen of the Cabinet Controller will allow resetting to normal function</p> <p>Scope timers will adjust storage times on resuming power and notify, on the Main Control Screen of the Cabinet Controller, if scopes need to be reprocessed in case of Storage Time-out or OOC Time-out expiry</p>
<p>PPE</p>	<p>Personal Protective Equipment</p>
<p>Print Station</p>	<p>A combination of a Display screen and Linux Controller, used with a Barcode scanner to “Scan Scope” and print status report (sticker identification label)</p>
<p>RotaScope Cabinet</p>	<p>An Endoscope Drying and Storage Cabinet. Features include: 9 scope Hang Hooks, independent HEPA filtered Air supply, a Data Management System, and accessories to enable the sustained storage of thermolabile endoscopes to meet Standard EN16442:2015</p>
<p>Router</p> 	<p>A data router connects multiple cabinets together and may connect to the Printer Station and Washer Station for collecting data from the process of washing a scope through the AER Washer or from a scope scanned at the printer</p> <p>The router may also play a role in notifications of errors by sending print message of system error if an error occurs – usually the router is located on or near the cabinets</p>
<p>Scope Connector Hose Kits</p>	<p>Also called “Vacuum Hoses” or “Hose Kits”</p> <p>Colour coded hoses with connection fittings – used to connect the cabinet airflow to various channel connection fittings of an endoscope, to dry endoscope lumens. Bought separately.</p>
<p>Scope Port</p>	<p>Also called Channel Connector, Channel Port, Scope Fitting, Button Ports or other names</p> <p>These connection fittings are small specific fittings on the scope umbilical plug or hand piece – they are used to connect air hoses or blockers to the scope enabling termination to the cabinet airflow or other fittings for flushing the endoscope channels internally.</p>
<p>Scope/s</p>	<p>Thermolabile Flexible Endoscopes</p>

SmartStation	A combination of a Display screen and Linux Controller, used with a Barcode scanner to "Scan the Operator and Scope" into and out of an AER Washer
X-Ray Door Kit	An X-ray proof optional door kit, may be fitted to Pass-Through Cabinets, to assist in the prevention of X-Rays being transmitted through the cabinet

## 3.6 Graphical Symbols

### 3.6.1 Explanation of graphical symbols in relation to the product

Symbol	Meaning
	Warning/Caution
	IEC Mains Power Supply
	CE Certification
	Date Of Manufacture
	FCC Compliance
	Instructions For Use Icon
	Indoor Use
	Medical Device
	RCM Compliance
	Batch Number Recorded
	ROHS Compliance
	Serial Number Recorded
	Unique Device Identifier
	IEC DC Powered

### 3.7 Personal Protective Equipment

PPE	Instruction
Gloves	To avoid potential contamination of endoscopes and internal surfaces it is recommended gloves are worn while interacting with the inside of a cabinet.
Scrubs	To avoid potential contamination of endoscopes and internal surfaces it is recommended scrubs are worn while interacting with the inside of a cabinet.
Gown	In the instance that scrubs are not in use, to avoid potential contamination of endoscopes and internal surfaces it is recommended gowns are worn while interacting with the inside of a cabinet.
Mask	To avoid potential contamination of endoscopes and internal surfaces it is recommended masks are worn while interacting with the inside of a cabinet.

## 4 PREPARATION

### 4.1 How to Transport and Store the Product

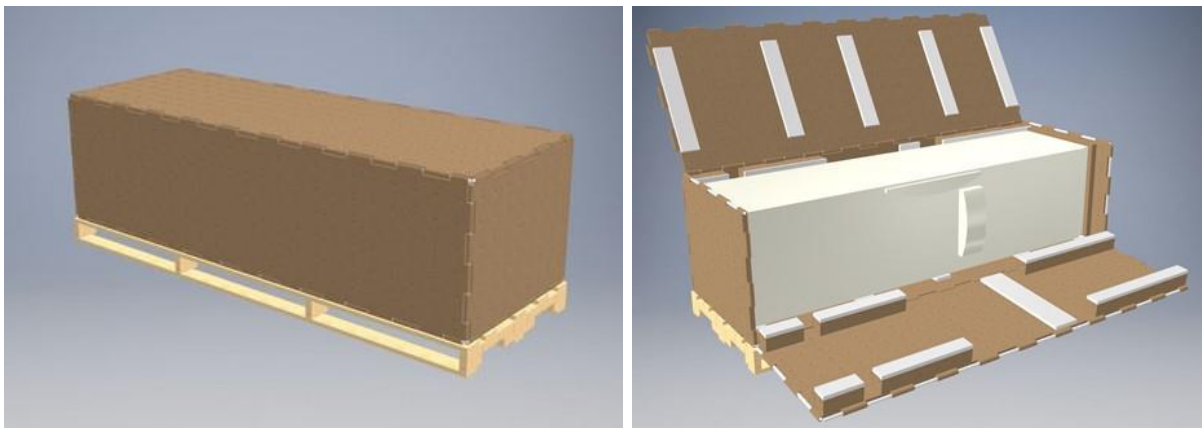
Cabinets and additional parts thereof are delivered in a dismantlable crate. Only suitably trained technicians should attempt the unloading and transporting the items.

While the cabinet remains in a crate, heavy lifting equipment must be used.

Non-commissioned cabinets should be stored in the corresponding crates or plastic film in a clean and dry area.

#### **⚠ WARNING**

**Do not attempt to lift cabinets without prior education and advice from a suitably trained technician.**



The cabinet is delivered in a crate 2453mmL x 852mmW x 775mmH which weighs approximately 190kg

The crate should only be moved with mechanical lifting aids or a forklift

The crate cardboard outer carton can be recycled – other materials should be disposed of in general waste bins

## 4.1.1 Dimensions, mass and center of gravity

**Cabinet Body** 600mm Wide x 600mm Deep x 2363mm High including Lid (Top Cap)

**Cabinet including Control screen** on Front Door 600mm Wide x 680mm Deep x 2363mm High

**Pass Through Cabinet** including Control Screen Front and Rear Door 600mm Wide x 760mm Deep x 2363mm High. Approximate Weight RotaScope 160Kg (107kg per m<sup>3</sup>)

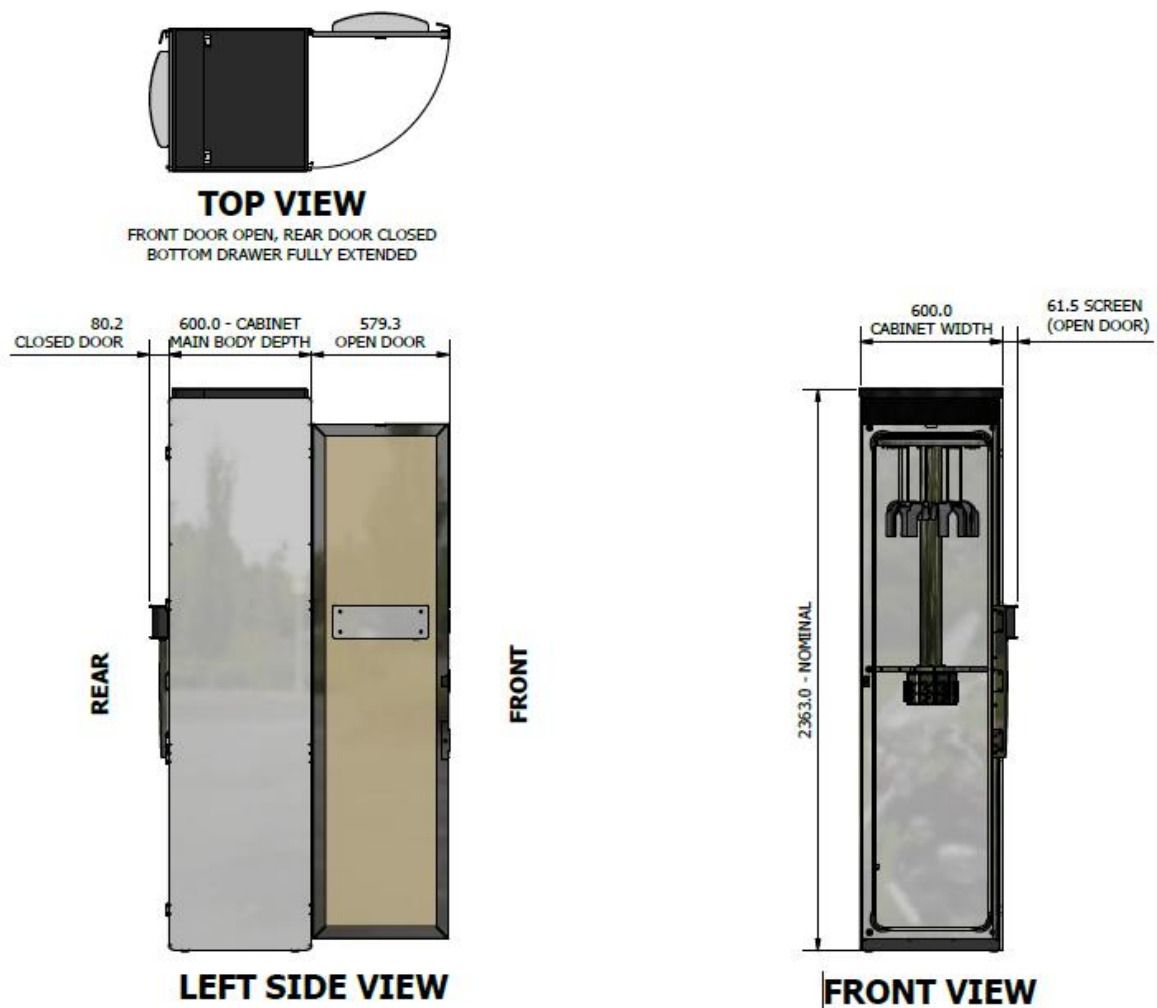


Fig. 3 – Cabinet Body Dimensions – note add depth of Screen or Screens (Front to Rear) for Single or Pass-Through doors

#### **4.1.2 Lifting, handing and transporting the product**

Prior to each installation, it is very important to confirm access to the location of the cabinets. Mapping the complete route to be sure that a cabinet can be moved through the department / hospital without obstacles / impediments is necessary, to ensure the installation can be completed within the allocated timeframe.

As the RotaScope Cabinet is of significant size, access on site can be of concern on occasion. Lifts being used for access must be at least **2500mm** in any one direction, and if not, it will have to be confirmed that the stairwell is an acceptable alternative route.

##### **To lift, handle or transport the product safely:**

Only attempt to lift it after receiving appropriate education from an Authorised Distributor

Always use lifting and mobility assistance devices

Never attempt to lift or move a cabinet without assistance (two persons minimum)

##### **Storing the product**

RotaScope cabinets should be installed and stored in continuous operating environment ie. Standard office working conditions need to be always provided. Room temperature range 10 C° to 30 C°, relative humidity between 40% and 70%.

##### **To store the product safely:**

Keep cabinet in crate until being transferred into desired installed position

If the cabinet needs to be removed from crate prior to install, maintain the protective packaging until install and store in a clean and dry location

Once installed, follow the standard cleaning regime

#### **4.1.3 Storing the product during intervals in normal use**

Once installed the cabinet should remain running when not in use and weekly cleaning regime should be maintained. If decommissioned or relocated, the cabinet must be handled and stored appropriately as per this manual and must be reinstalled and undergo a full or partial IQ, OQ and PQ. (Installation Qualification as described in EN16442:2015 Standards)

##### **To store the product during intervals in normal use:**

Cover the cabinet in a suitable temporary protective material.

Uncover at time of re-commissioning.

Complete IQ, OQ and PQ



**4.1.4 Securing the product against shocks**

Only use suitable shock protected power outlets, maintain a test and tag regime on power leads.

**4.1.5 Securing the product against electrical shock**

- Keep the cabinet free from liquids
- Maintain a suitable install environment
- Indoor use only

**4.1.6 Securing the product against impact**

- Keep the cabinet protected against hard bumps by people, trolleys and moving objects
- Maintain a suitable install environment
- Do not lean heavy objects against the cabinet

## 4.2 How to Install the Product

### **⚠ WARNING**

Installation of the Cabinet must be only done by a minimum of two suitably trained, approved installation technicians and under the supervision of an Approved Distributor

### 4.2.1 Removal of the transport and packaging restraints – unpacking the cabinet from the crate

The cabinets arrive on site in a crate which can be fully dismantled.

Follow the steps below to avoid injury:

#### Instructions to unpack:

### **⚠ WARNING**

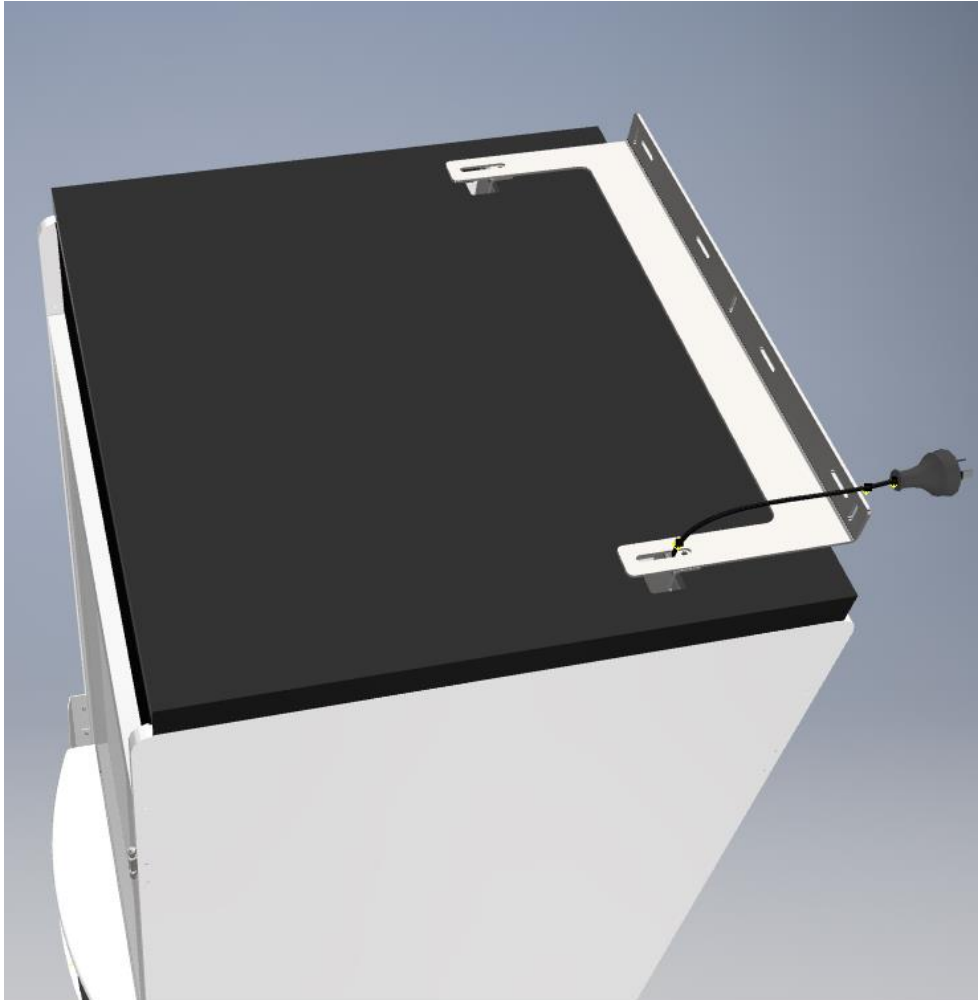
**Warning the RotaScope Cabinet is heavy weighing 140 kg**

1. Remove the packing straps by cutting the plastic straps with scissors
2. Wear eye protection when cutting straps to avoid eye damage if tight straps stray whilst being cut
3. Remove the outer cartons and dispose of, via a cardboard recycling bin
4. Unbolt the metal frames at the at each end of the packing crate by removing the retaining screws using a wrench – dispose of the metal frames into a Metal Recycling bin if possible
5. Remove the packing straps from around the cabinet and pallet base - dispose of in a General Waste Bin
6. Remove the cartons located at one end of the cabinet – The Cartons contain Baskets and ancillary devices in cartons – retain for use later
7. Remove the foam packaging edges from the cabinet and dispose of in a General Waste Bin
8. With two people, carefully slide the cabinet base past the end of the pallet so that you can stand the cabinet up
9. With two people stand the cabinet up on its feet and unpack the packaging material (Stretch wrap and foam insulation sheet)
10. Exercise extreme caution and practice safe lifting methods whilst standing the cabinet – dispose of the wrapping in general waste bin
11. Using a suitable lifting trolley or mechanical aids as needed – move the cabinet approximately into position.

**NOTE:** Not all cabinets have stickers on the cabinet sides as they may be assembled into groups of cabinets – select the appropriate cabinets so that stickers are positioned to be visible when finally installed. Usually, cabinets are numbered with serial numbers or identification – refer to the cabinet floor plan layout provided before install.

## 4.2.2 Free Standing Cabinet Wall Mount

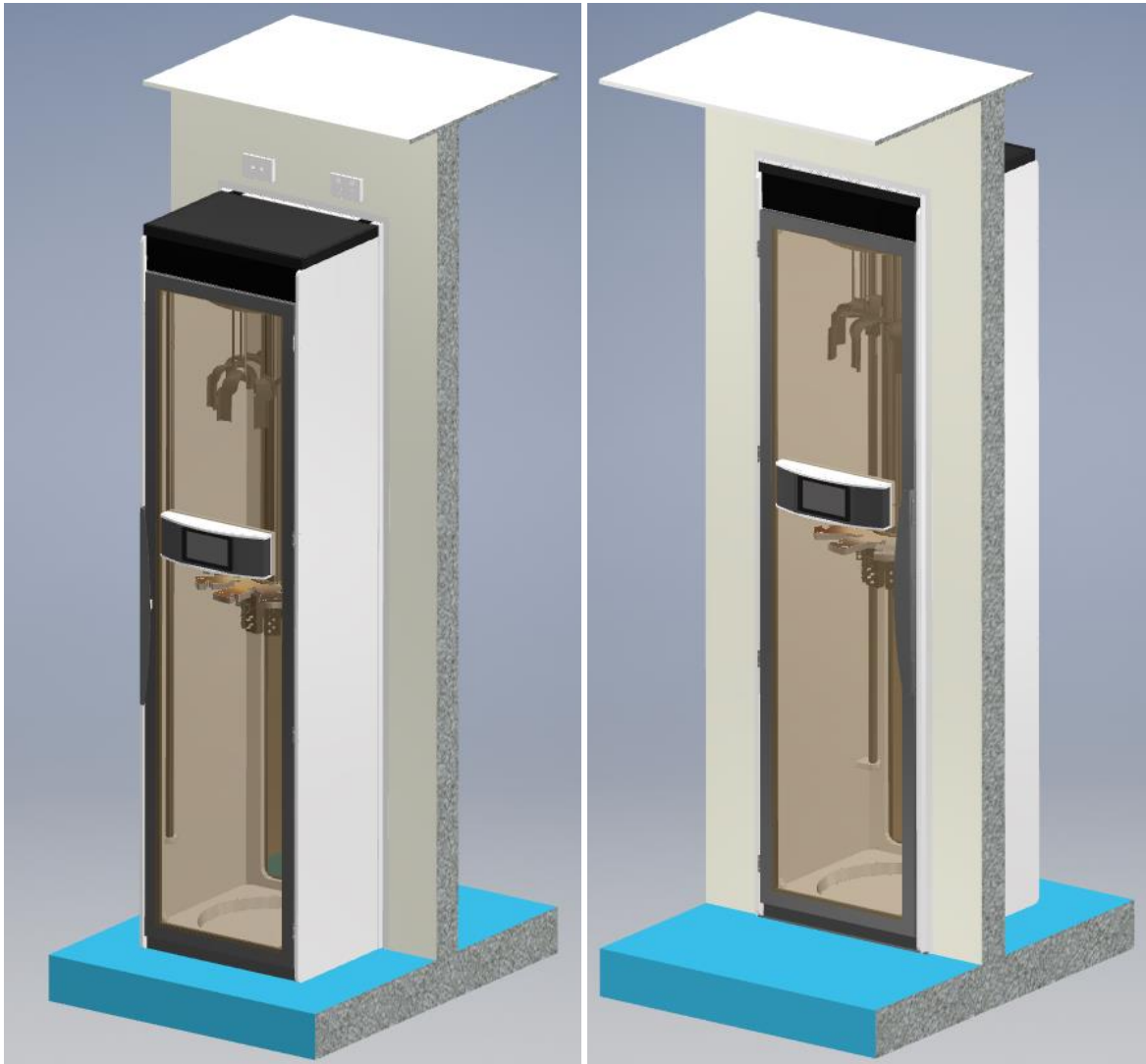
Single Door cabinets require the top of the cabinet to be mounted to the wall to ensure stability. The supplied bracket should be mounted to the top of the cabinet and secured to the wall, preferably into solid structure or stud. See below.



## 4.2.3 Pass Through Units

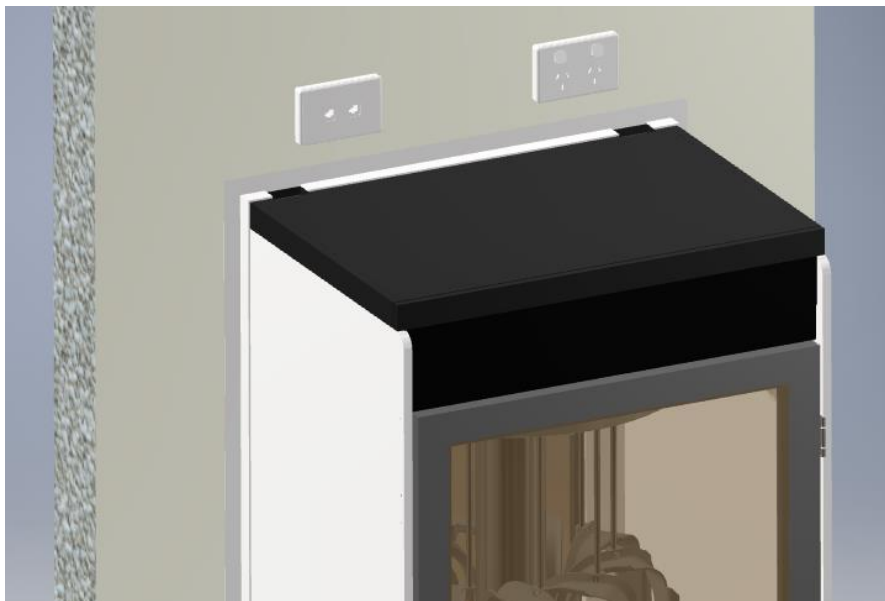
If specifically ordered, Pass-Through cabinets may be supplied with a rear door, which includes a display screen, and scanner. The function of the rear door screen is exactly the same as the front door screen. The rear door allows scopes to be loaded in the Reprocessing Room but unloaded in the Procedure Room (Operating Theatre). Power and data points should have been installed during building construction of the wall, so that cables neatly pass from the top of the cabinet to the power and datapoints. Consult appropriate wall cut out drawings in the Smartline Distributor Portal for wall cut out size and GPO positioning.

The cabinets are trimmed and neatly fitted into the wall with small flashings (Cover strips) that seal the cabinet into the wall preventing room air exchanging between the rooms. Ensure these are sealed to the cabinet and wall using silicone or a similar sealant.



***Cabinet Front located in the Reprocessing Room***

***Cabinet Rear seen in the Procedure Room***



### **X-Ray proof door kit:**

If a Pass-Through Scope Cabinet requires an X-Ray proofing, an X-Ray proof Door can be fitted to the cabinet. The shielding complies with a 10kg/m<sup>2</sup> Lead equivalence protection level, suitable for most theatres that perform X-Ray functions.



***X-Ray Proof Door shown***

### **4.2.4 Power Connection:**

1. Depending on the site layout and location of cabinets, plug in any SmartStations and cabinets by using ethernet cables and refer to the site layout drawing provided prior to install
2. Plug Cabinet power cord into a GPO
3. Plug SmartStation power cord into a GPO
4. Check the Cabinet ON/OFF switch (located on the side of the IAS) at the top of the cabinet
5. Cabinet will power up automatically upon receiving power

### **4.2.5 Packaging contents**

The cabinet will come with the following packaging materials:

- Treated timber pallet skid
- Cardboard Outer Carton
- Polystyrene corner foam
- Stretch plastic wrap
- Protective foam sheets
- Protective paper coating
- Metal Crate Ends

#### **4.2.6 Verification of the product**

At completion of install, a cabinet must be verified via the Authorised Distributor using the Smartline Medical approved Auditing Tools for an Installation and Operational Qualification (IQ & OQ) in accordance with EN16442 and AS4187 or local standard. Following this, a Performance Qualification (PQ) should be carried out by a suitably trained technician and is the responsibility of the HSO.

#### 4.2.7 Minimum space needed.

The cabinet has a total size of 600mm Wide x 600mm Deep x **2363mm** High and requires a minimum of 1200mm Deep and 2400mm Ceiling height and must not be installed less than 100mm from any wall. See diagram below.

Passthrough models require 1800mm deep.

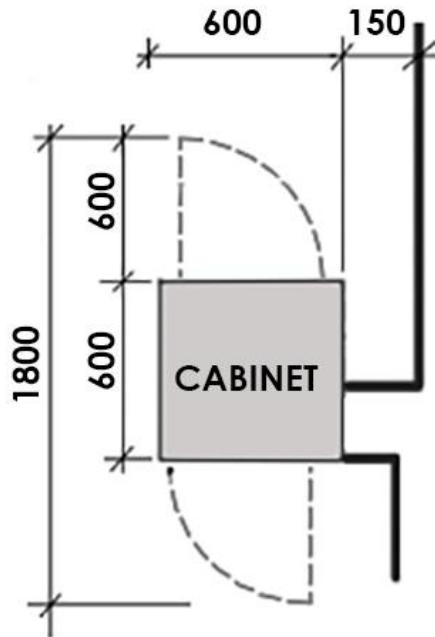


Fig. 4 – Spatial Requirements

## 4.2.8 Layout plan

Each Install Location requires a layout plan and schematic to be drawn prior to install.

A site layout and install document will be provided prior to installation for each site.

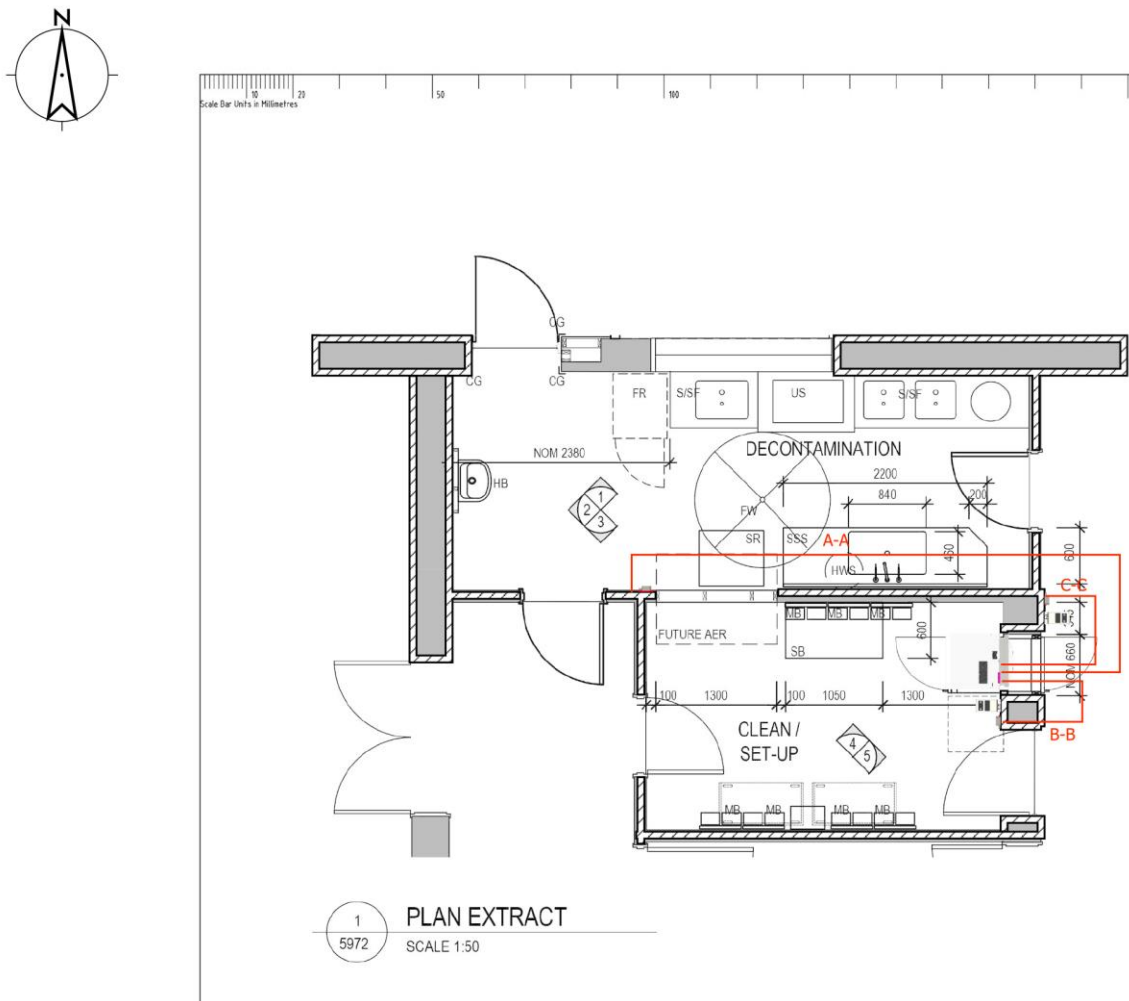


Fig. 5 – Example Layout Plan



## 4.2.9 Data and Power Schematic

Each install Requires a Data and Power Schematic prior to install

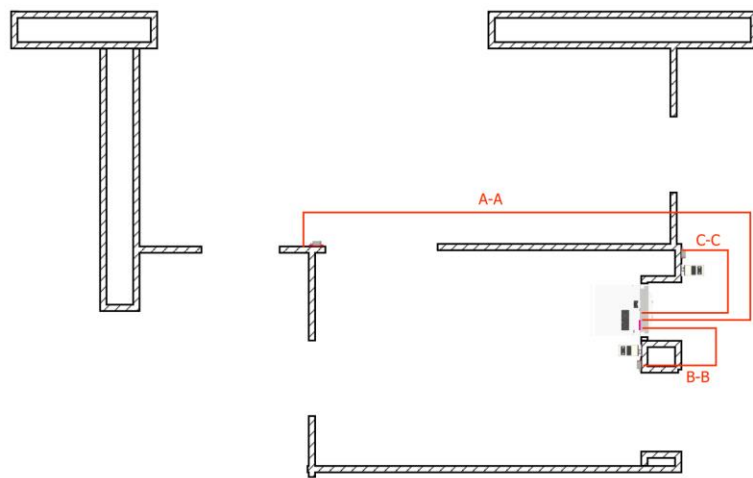
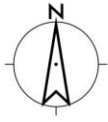


Fig. 6 -Example Data and Power Schematic

#### 4.2.10 Required Tools

### **⚠ WARNING**

**Never attempt to lift or move a cabinet without the appropriate training and support, always use two technicians to move and lift a cabinet.**

#### Required tools:

- Battery Drill/Driver (Philips Head No2 Driver)
- Level
- Shifter (adjustable wrench)
- Socket set
- Box Cutter (Stanley Knife or similar)
- Platform Ladder
- Dolly Trolley
- Screwdriver set
- Wall plugs (Dry wall anchors - Wall Mates)
- Stud Finder
- Hospital Grade Disinfectant

### 4.3 How to Commission the Product

Prior to use, the cabinet must undergo thorough disinfection firstly by the Approved Distributor and finally at a clinical level clean should be performed by the Hospital/Departmental Staff.

In-service training will be carried out by an appropriate training provider and is supplemented by video training.

#### 4.3.1 Installation of the software

- All cabinets are provided with pre-installed software.
- See also Communication Kit – If supplied, the laptop computer is loaded with the Scope Manager Software and is used for basic setup of Operator ID Barcodes and Scope ID Barcodes.
- Scope Manager Software may be supplied by the Authorised Distributor and may be installed onto a hospital provided PC under the supervision of the Authorised Distributor

#### 4.3.2 Calibration of the device

### **⚠ WARNING**

**Calibration of the cabinet will be done firstly inhouse at the commencement of manufacture and is checked again during the Install and Operational Qualification (IQ,OQ) by the Authorised Distributor.**

## 5 OPERATION/USE Verification

### **⚠ WARNING**

#### **How to Verify Correct Installation and Operation of the Device:**

##### **5.1.1 Verification of correct installation**

Follow the IQ and OQ procedure as per EN16442:2015 Standards – this should be performed by the Authorised Distributor

##### **5.1.2 Verification of correct maintenance**

Manage the annual servicing requirements via an Annual Service Agreement

##### **5.1.3 Verification of correct cleaning/disinfection.**

Arrange the correct PQ (Performance Qualification) to be done in accordance with EN16442 or local standard.

##### **5.1.4 Operational environment**

The cabinet should only be used indoors and in a controlled environment of 0 – 35 Degrees Celsius

##### **5.1.5 Using the device in combination with other devices**

The Cabinets are designed to only be used with Smartline approved devices including the SmartStation (printer) and Communications kit PC. (See section in this manual – SmartStation **2.12** and Communications Kit **2.12.3**)

##### **5.1.6 Instructions for devices emitting hazardous radiation**

Zebra LS2208 Laser Barcode Readers are used with the cabinet system

Laser safety: - Laser CDRH Class II; IEC Class 2, 5.0 V DC, 200 mA

##### **5.1.7 Instruction for devices that are composed of substances or of combinations of substances that are intended to be introduced into the human body**

– Not applicable

##### **5.1.8 Manual operating techniques**

A Hard Reset function may be carried out by the user should there be a need to do so, typically instructed by an Authorised Distributor

- Push the reset button located at the top of the cabinet behind the front façade
- The Data system and cabinet air system will restart after a Hard Reset

- The storage times and stored Scope Information will not be lost by performing a Hard Reset

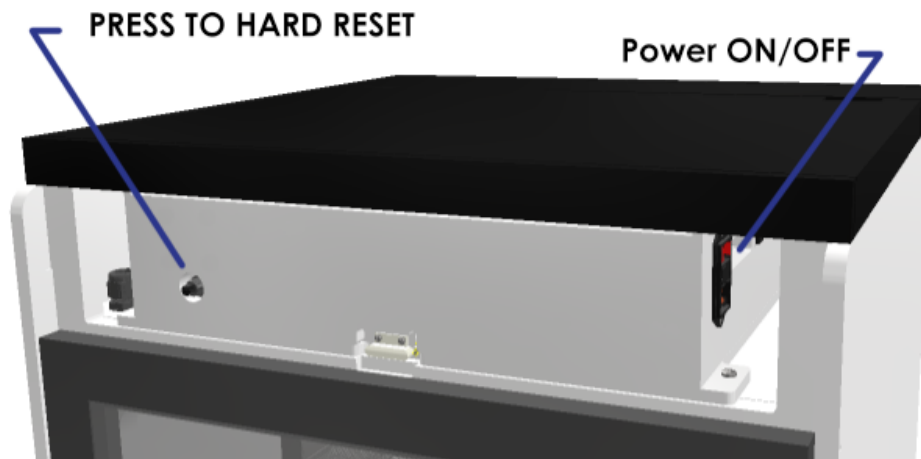


Image above shows use of the "Hard Reset Button", located behind the façade at the top front of the RotaScope Cabinet

### 5.1.9 Starting/Stopping the product operation

To Start and Stop the products operation, simply remove power to the cabinet via the GPO.

Alternatively – a fused power switch is located on the side of the IAS (Integrated Air System) which incorporates the electronic control devices of the Cabinet Control System. The IAS is located on the top of the cabinet behind the removable façade.

## 5.2 How to Use the Product Remotely/Automatically

### **⚠ WARNING**

**Advanced operations shall only be done by an Authorised Distributor.**

For remote service and access to advanced cabinet settings – please contact your local Authorised Distributor

## 5.3 What to Do in Emergency and Exceptional Situations

If the cabinet goes into an alarm state and cannot be rectified, contact your local Authorised Distributor

### **In case of an emergency:**

- Turn off the device
- Contact your local Authorised Distributor

## 6 MAINTENANCE

### **⚠ WARNING**

The RotaScope shall only be maintained by a qualified and trained Authorised Distributor

#### How to Maintain the Product

##### 6.1.1 Planned maintenance of RotaScope.

Maintenance tasks shall be done according to the following plan:

Task	Frequency
Replacing the Intake Filter	Every 12 months
Replacing HEPA Filter	Every 12 months
Replacing the Air Pumps	Every 24 months

## 6.2 How to Inspect the Product

### 6.2.1 Weekly inspection tasks

Task	Action
Weekly Cabinet Clean	Use Hospital Grade Disinfectant to wipe over every internal surface of the cabinet as per the IFU in this manual
Weekly Scope Hose Connection Set Clean (Clean Hoses or swap-out with a previously cleaned hose kit)	Remove and replace hoses from cabinet and have them disinfected using the manual or automated disinfection process as per the IFU in this manual

## 7 TROUBLESHOOTING AND REPAIR

### **⚠ WARNING**

All repairs should be done by an Authorised Distributor.

### 7.1 How to Identify and Solve Problems

#### 7.1.1 Troubleshooting and repair by non-skilled persons

If an issue cannot not be resolved by the following troubleshooting guide, please contact your Authorised Distributor and a service technician will be in contact to troubleshoot or attend your site if required.

Error	Cause	Solution
Product does not start	Power Failure / Blown Fuse / Electronic Failure	Restore Power and reset via "Alarm Acknowledge Button" on Cabinet Control Screen  Or replace a part via a service technician
Cabinet WHITE Lights Stays On	Door Open	Close Door
Cabinet lights colour is not GREEN	Refer to cabinet lighting guide Green – Normal Operation White – Door Open Purple – Power failure Orange – Warning Red – Failure Blue – Clean Due	Green – all OK White – Close Door Purple – Clear alarm via Cabinet Control Screen Alarm Acknowledge Button Orange – check for cause of default and rectify eg Door Open too long Red – Failure – see visible alarm or print out warning Blue – Perform cabinet Clean and reset via scanning Operator Tag

## 7.2 Frequently Asked Questions

Question	Answer
Why is my cabinet purple?	There has been a power outage, you need to acknowledge this alarm via the control panel on the door touchscreen. Following this be sure to check if the stored endoscopes are within their allocated storage timeframe.

## 7.3 Repair

### 7.3.1 Repair by skilled persons

**⚠ WARNING**

All repairs must be done by an Authorised Distributor.

## 8 DISPOSAL

Prior to disposal, the cabinet must undergo a thorough disinfection.

### 8.1 How to Disassemble the Product

#### To disassemble the product:

Disassemble the Cabinet into obvious assemblies using basic hand tools

- a) Remove Acrylic Lid Top Caps – separate with other Acrylic materials e.g. Cabinet Body
- b) Remove Aluminium Doors and Discard Door Seals – remove acrylic clear panel and group with acrylic parts – separate door control screen housing assembly – group aluminium door with metal items – group steel handle with metal parts - remove hinges and group with metal parts - group acrylic panel with other acrylic items e.g. cabinet housing – remove door lock and cables and group with electrical items
- c) Remove rear Closing Panel and Discard Door Seals
- d) Disassemble Control Screen and housing separating electronic parts from Acrylic plastic housing and metal façade -group metal façade with other metal parts – group acrylic housing with acrylic parts – group electrical parts with other electrical parts
- e) Remove IAS – separate Acrylic lid and housing from electrical parts – group Acrylic with other Acrylic parts – group electrical parts – dispose of insulation, stickers, filter, and silicone hoses
- f) Remove Stainless parts and group with metal parts
- g) Remove Acrylic Centre Disks - Group disks with other Acrylic parts – remove manifolds and separate electronic boards with electronic parts – remove manifold body parts and group with Acetal plastic parts – discard plastic luer nipples and silicone seals
- h) Remove stainless steel air tube from cabinet body – group metal parts
- i) Remove remaining electrical cables and cable glands and ducting from cabinet and group electrical components with other electrical components – dispose of ducts and cable glands
- j) Remove cabinet leveling feet and group with metal parts, dispose of plastic feet caps
- k) Acrylic Cabinet Shell - Remove external stickers and any remaining decals, screws or miscellaneous items – dispose of stickers and decals – group any remaining items e.g. electrical or metal
- l) All metal screws can be grouped with metal objects

Group the remaining materials in matched groups – Acrylic plastic parts, metals, electrical cables, electronic boards, batteries, Acetal manifolds,

Make safe the storage of grouped items for assessment by various disposal or recycle agents



## 8.2 How to Recycle Parts

See in conjunction with 8.3 Safe disposal of product

### To recycle part A: Acrylic Plastics

1. Contact a plastic recycling company
2. Gather and Assess Acrylic Plastic with representative
3. Dispatch goods to recycle company as agreed upon inspection

### To recycle part B: Metals

1. Contact Metal recycling Company
2. Gather and separate all metals into types – eg Stainless steel – Mild Steel – Aluminum – Assess metals with representative
3. Dispatch goods to recycle company as agreed upon inspection

### To recycle part B: Electrical/Electronic

1. Contact an electrical parts recycle Company
2. Separate and gather electronic control boards motors, cables and fittings – assess with a representative
3. Dispatch goods to a recycle company as agreed upon inspection

## 8.3 How to Dispose the Product

### **⚠ WARNING**

#### 8.3.1 Test procedure to facilitate safe disposal of the device and related waste substances

Devices are designed and manufactured to facilitate safe disposal and the safe disposal of related waste substances by the user, patient, or other people. Manufacturers have identified test procedures and measures relating to disposal, so devices can be safely disposed after use. Such procedures are described below.

#### To test the product before disposal:

1. Ensure that the product and accessories were cleaned and disinfected prior to disposal.
2. Confirm that cleaning was done.
3. Confirm that the person responsible for disassembly and disposal, have been advised that the product is clean and safe to dispose of.

### 8.3.2 Disposal of the device

To dispose the device: Confirm that your facility has resources and trained personnel to disinfect than disassemble the product for selective recycling in conjunction with selected recycling representatives.

### 8.3.3 Disposal of waste substances:

#### **⚠ WARNING**

- Confirm all items have been cleaned and disinfected prior to disposal
- Check recycling labels for instruction
- Only dispose of items that are for general waste and not to be recycled
- Discard general waste via HSO waste policy

### 8.3.4 Disposal of electronic components

The symbol on the product, the accessories or packaging indicates that this device must not be treated as unsorted municipal waste but must be collected separately! Dispose of the device via a collection point for the recycling of waste electrical and electronic equipment if you live within the EU and in other European countries that operate separate collection systems for waste electrical and electronic equipment. By disposing of the device in the proper manner, you help to avoid possible hazards for the environment and public health that could otherwise be caused by improper treatment of waste equipment. The recycling of materials contributes to the conservation of natural resources. Therefore, do not dispose of your old electrical and electronic equipment with the unsorted municipal waste.



#### **To dispose electronic components:**

1. Separate electronic components
2. Identify the type of product or seek advice on disposal from an expert
3. Dispose of according to HSO waste disposal regulation

### 8.3.5 Disposal of packaging waste

The packaging is made of environmentally friendly materials, which may be disposed through your local recycling facilities. By disposing of the packaging and packaging waste in the proper manner, you help to avoid possible hazards for the environment and public health. The symbol on the packaging indicates what the packaging material is made of.

#### **To dispose packaging waste:**

1. Separate materials into wood, cardboard, metal, general waste
2. Check HSO waste management guidelines
3. Recycle and dispose of product by category

### **8.3.6 Disposal of batteries**

The product contains a CR2032 battery in the IAS. Batteries may not be disposed of with the usual domestic waste. They may contain toxic heavy metals and are subject to hazard our waste regulations. For this reason, dispose of used batteries at a local collection point.

#### **To dispose batteries**

1. Gather batteries
2. Identify type and recycling method
3. Dispose of batteries at local collection point

## 9 APPENDIX I – SUPPLIED ACCESSORIES, CONSUMABLES AND SPARE PARTS


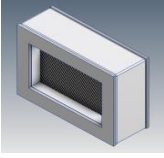
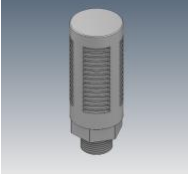
### 9.1 Supplied accessories

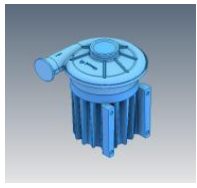
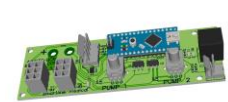
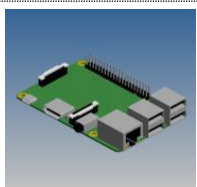
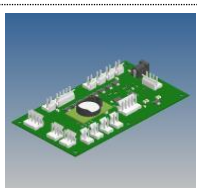


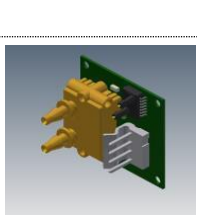
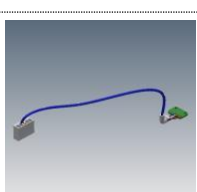
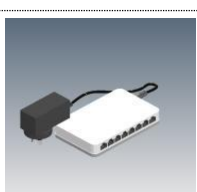
Image	Name	ID
	Hose Connection Kits	Various
	Communication Kit	COMMUNICATION KIT
	Labels	N/A


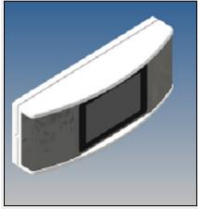


### 9.2 Consumables

Image	Name	Part Number
	Tip Protector	TIP PROTECTORS
	Channel Separators	See Authorised Distributor

### 9.3 Spare/replacement parts

Image	Name	Part Number
	FUSE 6.3A – Fuse holder at IEC Power Cable Socket	Contact Smartline
	HEPA Filter in IAS	HEPA FILTER H13
	Intake Air Filter in IAS	47.AN302

	Air Pump x2 in IAS	MINIATURE RADIAL BLOWER
	Pump Motor Control Board in IAS	MOTOR CNTRL BOARD 24VDC
	Raspberry Pi in IAS/Door Blister	48.2525226
	IO Power Board in IAS	IAS CABINET INTERFACE BOARD
	24v Transformer in IAS	TRANSFORMER MCC 24V
	12v Power Supply in IAS	48.MP3490
	Vacuum Sensor in IAS	48.SC-CE-PVM
	Cabinet pressure monitor in IAS	48.SC-SY-HTS
	Data Switch/power pack in IAS	48.DGS-1008A

	<p>Door Lock/Latch – in door frame</p>	<p>LOCK SOLENOID</p>
	<p>Door Cabinet Control Blister Assembly – On cabinet door - BLACK - SILVER</p>	<p>DOOR BLISTER IQ BLACK DOOR BLISTER SVR</p>
	<p>Power Board</p>	<p>48.SC-CE-PCB</p>
	<p>CR2032 Battery</p>	<p>Contact Smartline</p>

## 10 DECLARATION OF CONFORMITY FOR CLASS I DEVICE

Manufacturers of class I devices, other than custom-made or investigational devices, shall declare the conformity of their products by issuing the EU declaration of conformity referred to in Article 19 after drawing up the technical documentation set out in Annexes II and III

Unique identification number of this Document: See Document no. F-218

### Manufacturer Detail

Business name: **Smartline Medical**  
Registered trade name  
or trademark: **SMARTLINE  
MEDICAL  
Smartline Medical Pty Ltd**  
Address: **55 Cordwell Rd, Yandina Qld, 4561**  
Country: **Australia**

### Declare under our sole responsibility that the device:

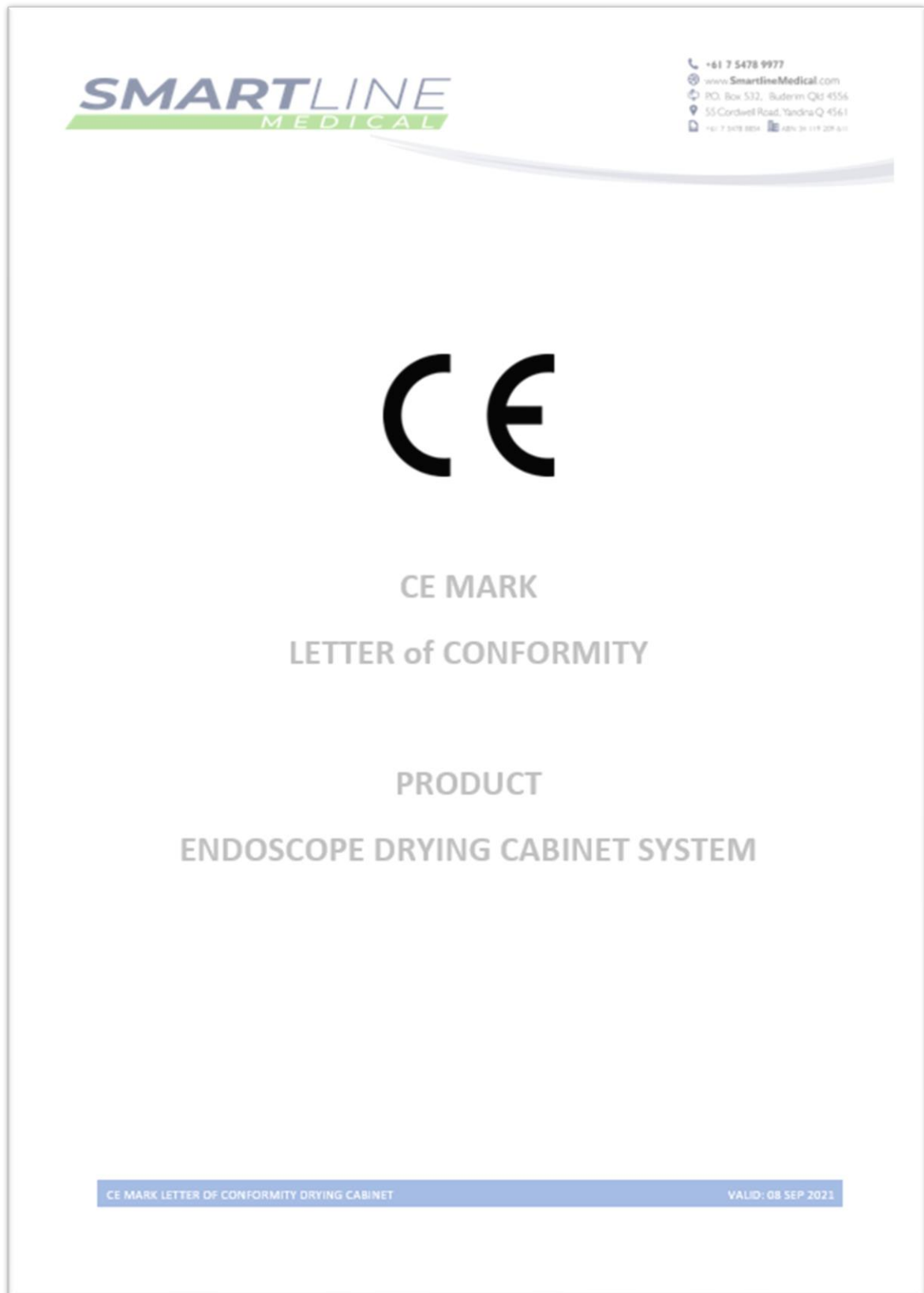
Basic UDI-DI: **9356523xxxx**  
Device name/Trade name: **RotaScope Cabinet**  
Product code: **ROTA-**  
Catalogue number: **N/A**  
Intended purpose: **A dedicated range of cabinets designed to dry and store flexible endoscopes in a clean storage environment that prevents bacterial growth after processing. Scopes are dried internally and externally by independently supplied clean HEPA filtered forced air. The cabinet is environmentally controlled to ensure scopes can be used directly without need for re-disinfection. The product is also equipped with clear doors (single door, pass through, or pass through X-Ray) and the option of either hooks or shelves to place several endoscopes. The product is approved for 31 days of continuous storage if an EN16442 model is selected.**

Object (colour image):

Complies with CE European Directives 2021 – see F218




**CE Declaration of Conformity 2021: P1**





## CE Declaration of Conformity 2021: P2



+61 7 5478 9977  
www.SmartlineMedical.com  
PO. Box 532, Buderim QLD 4556  
55 Cordwell Road, Yandina Q 4561  
+61 7 5478 9977 ABN 24 119 209 611

### Declaration of Conformity

For the following equipment:

Product Description: Endoscope Drying Cabinet System

Including Model No's:

- ROTA- (all models)
- SLIDA- (all models)
- IAS

Trademark: Smartline Medical Pty Ltd Trading as Smartline Medical

We declare under our own responsibility that the above products satisfy all the technical regulations applicable to the product within the scope of Council Directives:


**Directives:**

MDR EU2017/745  
EU EMC Directive 2014/30/EU  
EU RoHS Directive 2011/65/EU

The above product is in conformity with the following standards or other normative documents:

- EN 61000-6-3:2011 Emissions
- EN61000-6-1:2007 Immunity
- AS/NZS 61000.6.3:2012 Australian EMC Framework
- EN 50581:2012
- EN16422:2015 Compliant
- AS/NZS 4187:2014
- ISO 9001 V2015

The product is entitled to bear the CE Mark



Person responsible for making this declaration

William Smart

8<sup>th</sup> September 2021

Director

CE MARK LETTER OF CONFORMITY DRYING CABINET

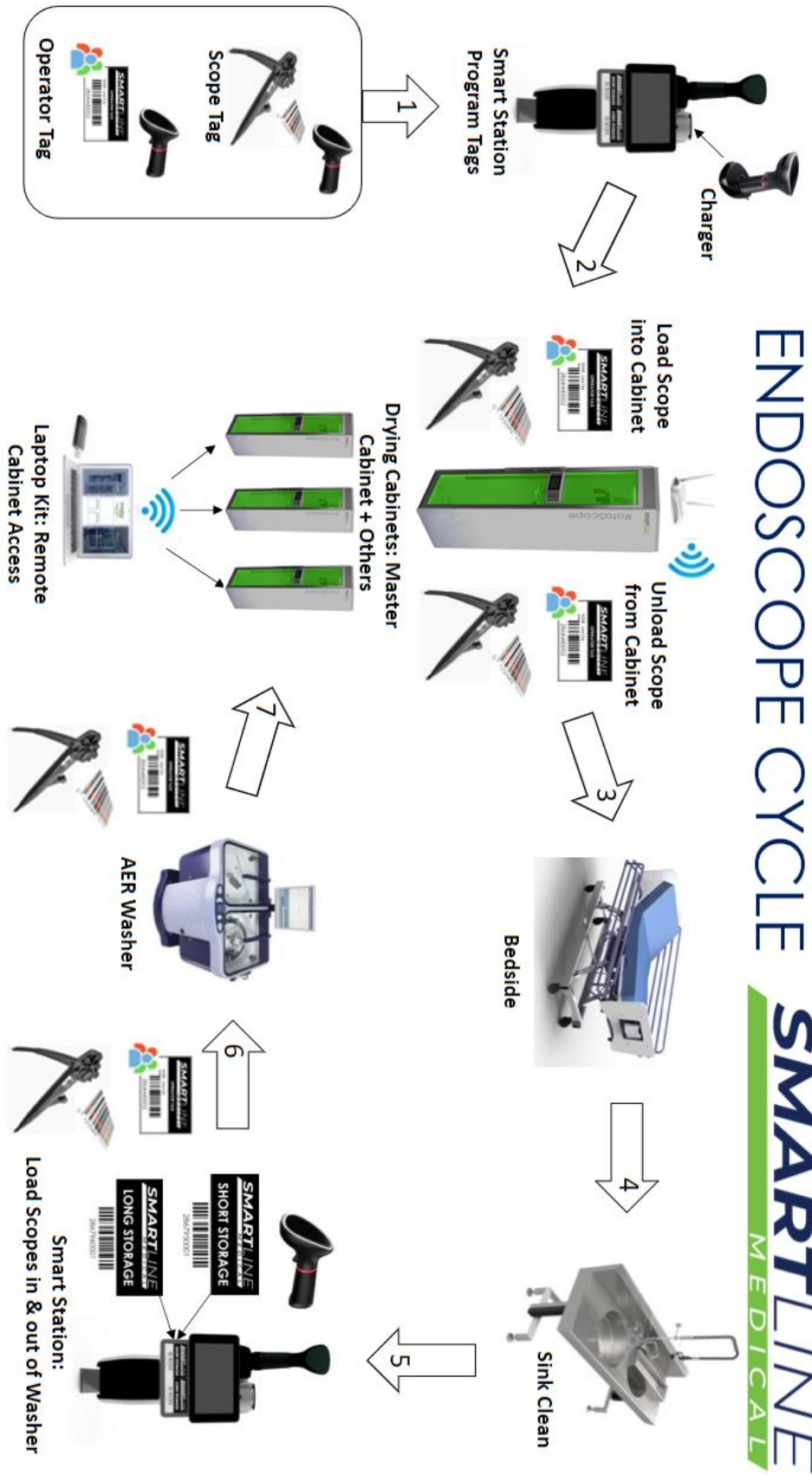
VALID: 08 SEP 2021

## RELATED DOCUMENTATION

#	Document Title	Version #	Location	Author
1	ApprovedScopeList.pdf	Aug 2021	<a href="mailto:sales@smartlinemedical.com">sales@smartlinemedical.com</a>	DW
2	CE Declaration Of Conformity F-218 V1	V1	<a href="mailto:sales@smartlinemedical.com">sales@smartlinemedical.com</a> Attached	WS
3	Workflow Overview	2021	<a href="mailto:sales@smartlinemedical.com">sales@smartlinemedical.com</a> Attached	DM
4	Barcode Setup Overview	2021	<a href="mailto:sales@smartlinemedical.com">sales@smartlinemedical.com</a> Attached	DM

NOTE: This Manual will be frequently updated with additional information FAQ questions and more – please refer to your Authorised Distributor for updated versions

## Workflow Overview



# ENDOSCOPE CYCLE SMARTLINE MEDICAL

## Barcode Setup Overview

